

NEHRU COLLEGE OF ENGINEERING AND RESEARCH CENTRE

(Accredited by NAAC, Approved by AICTE New Delhi, Affiliated to APJKTU)

Pampady, Thiruvilwamala(PO), Thrissur(DT), Kerala 680 588

DEPARTMENT OF MECHATRONICS



LAB MANUAL



MRL331

PLC AND DATA ACQUISITION

VISION OF THE INSTITUTION

To mould true citizens who are millennium leaders and catalysts of change through excellence in education.

MISSION OF THE INSTITUTION

NCERC is committed to transform itself into a center of excellence in Learning and Research in Engineering and Frontier Technology and to impart quality education to mould technically competent citizens with moral integrity, social commitment and ethical values.

We intend to facilitate our students to assimilate the latest technological know-how and to imbibe discipline, culture and spiritually, and to mould them in to technological giants, dedicated research scientists and intellectual leaders of the country who can spread the beams of light and happiness among the poor and the underprivileged.

ABOUT DEPARTMENT

- ◆ Established in: 2013
- ◆ Course offered: B.Tech Mechatronics Engineering
- ◆ Approved by AICTE New Delhi and Accredited by NAAC
- ◆ Affiliated to the University of Dr. A P J Abdul Kalam Technological University.

DEPARTMENT VISION

To develop professionally ethical and socially responsible Mechatronics engineers to serve the humanity through quality professional education.

DEPARTMENT MISSION

MD 1: The department is committed to impart the right blend of knowledge and quality education to create professionally ethical and socially responsible graduates.

MD 2: The department is committed to impart the awareness to meet the current challenges in technology.

MD 3: Establish state-of-the-art laboratories to promote practical knowledge of mechatronics to meet the needs of the society.

PROGRAMME EDUCATIONAL OBJECTIVES

- PEO1:** Graduates shall have the ability to work in multidisciplinary environment with good professional and commitment.
- PEO2:** Graduates shall have the ability to solve the complex engineering problems by applying electrical, mechanical, electronics and computer knowledge and engage in lifelong learning in their profession.
- PEO3:** Graduates shall have the ability to lead and contribute in a team with entrepreneur skills, professional, social and ethical responsibilities.
- PEO4:** Graduates shall have ability to acquire scientific and engineering fundamentals necessary for higher studies and research.

PROGRAM OUTCOMES (PO'S)

Engineering Graduates will be able to:

PO 1. Engineering knowledge: Apply the knowledge of mathematics, science, engineering fundamentals, and an engineering specialization to the solution of complex engineering problems.

PO 2. Problem analysis: Identify, formulate, review research literature, and analyze complex engineering problems reaching substantiated conclusions using first principles of mathematics, natural sciences, and engineering sciences.

PO 3. Design/development of solutions: Design solutions for complex engineering problems and design system components or processes that meet the specified needs with appropriate consideration for the public health and safety, and the cultural, societal, and environmental considerations.

PO 4. Conduct investigations of complex problems: Use research-based knowledge and research methods including design of experiments, analysis and interpretation of data, and synthesis of the information to provide valid conclusions.

PO 5. Modern tool usage: Create, select, and apply appropriate techniques, resources, and modern engineering and IT tools including prediction and modeling to complex engineering activities with an understanding of the limitations.

PO 6. The engineer and society: Apply reasoning informed by the contextual knowledge to assess societal, health, safety, legal and cultural issues and the consequent responsibilities relevant to the professional engineering practice.

PO 7. Environment and sustainability: Understand the impact of the professional engineering solutions in societal and environmental contexts, and demonstrate the knowledge of, and need for sustainable development.

PO 8. Ethics: Apply ethical principles and commit to professional ethics and responsibilities and norms of the engineering practice.

PO 9. Individual and team work: Function effectively as an individual, and as a member or leader in diverse teams, and in multidisciplinary settings.

PO 10. Communication: Communicate effectively on complex engineering activities with the engineering community and with society at large, such as, being able to comprehend and write effective reports and design documentation, make effective presentations, and give and receive clear instructions.

PO 11. Project management and finance: Demonstrate knowledge and understanding of the engineering and management principles and apply these to one's own work, as a member and leader in a team, to manage projects and in multidisciplinary environments.

PO 12. Life-long learning: Recognize the need for, and have the preparation and ability to engage in independent and life-long learning in the broadest context of technological change.

PROGRAM SPECIFIC OUTCOMES (PSO'S)

PSO 1: Design and develop Mechatronics systems to solve the complex engineering problem by integrating electronics, mechanical and control systems.

PSO 2: Apply the engineering knowledge to conduct investigations of complex engineering problem related to instrumentation, control, automation, robotics and provide solutions.

CODE	COURSE NAME	CATEGORY	L	T	P	CREDIT
			0	0	3	
MRL331	PLC AND DATA ACQUISITION LAB	PCC	0	0	3	2

Preamble: This course enables students to practice the applications of data acquisition and PLC systems experimentally.

Prerequisite: MRT 305 PLC AND DATA ACQUISITION SYSTEMS

Course Outcomes: After the completion of the course the student will be able to

CO 1	Experimentally test and familiarize the characteristics of strain gauge , load cell, LVDT, thermocouple, thermostat and LDR using measurements kits
CO 2	Understand about basics of PLC
CO 3	Implement the PLC program for logic gates and flipflops and apply in hardware and simulation
CO 4	Simulate and implement various control operations using PLC hardware and software

Mapping of course outcomes with program outcomes

	PO 1	PO 2	PO 3	PO 4	PO 5	PO 6	PO 7	PO 8	PO 9	PO 10	PO 11	PO 12
CO 1	3	-	2	-	-	-	-	-	3	-	-	2
CO 2	3	-	2	-	-	-	-	-	3	-	-	2
CO 3	3	2	3	2	3	-	-	-	3	-	-	3
CO 4	3	3	3	3	3	-	-	-	3	-	-	3

Assessment Pattern

Mark distribution

Total Marks	CIE	ESE	ESE Duration
150	75	75	2.5 hours

Continuous Internal Evaluation Pattern:

Attendance : 15 marks
 Continuous Assessment : 30 marks
 Internal Test (Immediately before the second series test) : 30 marks

End Semester Examination Pattern: The following guidelines should be followed regarding award of marks

(a) Preliminary work

: 15 Marks

SYLLABUS	
(b) Implementing the work/Conducting the experiment	: 10 Marks
(c) Performance, result and inference (usage of equipments and trouble shooting)	: 25 Marks
(d) Viva voce	: 20 marks
(e) Record	: 5 Marks
<p>General Instructions: Practical examination to be conducted immediately after the second series test covering entire syllabus given below. Evaluation is a serious process that is to be conducted under the equal responsibility of both the internal and external examiners. The number of candidates evaluated per day should not exceed 20. Students shall be allowed for the University examination only on submitting the duly certified record. The external examiner shall endorse the record.</p>	
Course Level Assessment Questions	
Course Outcome 1 (CO1):	
<ol style="list-style-type: none"> 1. What is the role of LVDT in data acquisition? What are its characteristics? 2. What do you infer from the strain gauge characteristics? 3. How can you make use of thermocouple in data acquisition? 	
Course Outcome 2 (CO2)	
<ol style="list-style-type: none"> 1. Draw and explain a ladder diagram. 2. What are the commercially available PLCs? 3. Explain the working of a PLC. 	
Course Outcome 3(CO3):	
<ol style="list-style-type: none"> 1. Implement a universal gate using PLC. 2. Implement a counter using PLC. 3. Implement the SR flip flop using PLC. 	
Course Outcome 4 (CO4):	
<ol style="list-style-type: none"> 1. Implement a timer circuit for traffic signal control using PLC. 2. Implement a level control circuit for an overhead tank using PLC. 3. Develop a controller for stepper motor control using PLC. 	
LIST OF EXPERIMENTS :(Minimum 12 experiments is mandatory)	
<ol style="list-style-type: none"> 1. Strain gauge characteristics 2. Load cell characteristics 3. LVDT characteristics 4. Characteristics of thermocouples 5. Characteristics of RTD 6. Characteristics of thermostats 	

7. LDR and opto coupler characteristics
8. AD590 Characteristics
9. Capacitive transducer characteristics
10. Study of PLC
11. Implementation of logic gates using PLC
12. Implementation of Flip flops using PLC
13. Implementation of timers and counters using PLC
14. Tank level control using PLC – simulation
15. Sequential switching of motors using PLC simulation
16. To construct sequencer using bit logic instruction only

Text Books

1. Hughes . T, "Programmable Logic Controllers" , ISA press, 1989
2. Petrezeulla, "Programmable Logic Controllers", McGraw Hill, 1989.
3. Curtis D. Johnson, " Process Control Instrumentation Technology", 8th edition Prentice Hall June 2005

PREPARATION FOR THE LABORATORY SESSION
GENERAL INSTRUCTIONS TO STUDENTS

1. Read carefully and understand the description of the experiment in the lab manual. You may go to the lab at an earlier date to look at the experimental facility and understand it better. Consult the appropriate references to be completely familiar with the concepts and hardware.
2. Make sure that your observation for previous week experiment is evaluated by the faculty member and you have transferred all the contents to your record before entering to the lab/workshop.
3. At the beginning of the class, if the faculty or the instructor finds that a student is not adequately prepared, they will be marked as absent and not be allowed to perform the experiment.
4. Bring necessary material needed (writing materials, graphs, calculators, etc.) to perform the required preliminary analysis. It is a good idea to do sample calculations and as much of the analysis as possible during the session. Faculty help will be available. Errors in the procedure may thus be easily detected and rectified.
5. Please actively participate in class and don't hesitate to ask questions. Please utilize the teaching assistants fully. To encourage you to be prepared and to read the lab manual before coming to the laboratory, unannounced questions may be asked at any time during the lab.
6. Carelessness in personal conduct or in handling equipment may result in serious injury to the individual or the equipment. Do not run near moving machinery/equipment's. Always be on the alert for strange sounds. Guard against entangling clothes in moving parts of machinery.
7. Students must follow the proper dress code inside the laboratory. To protect clothing from dirt, wear a lab coat. Long hair should be tied back. Shoes covering the whole foot will have to be worn.
8. In performing the experiments, please proceed carefully to minimize any water spills, especially on the electric circuits and wire.
9. Maintain silence, order and discipline inside the lab. Don't use cell phones inside the laboratory.
10. Any injury no matter how small must be reported to the instructor immediately.

11. Check with faculty members one week before the experiment to make sure that you have the handout for that experiment and all the apparatus.

AFTER THE LABORATORY SESSION

1. Clean up your work area.
2. Check with the technician before you leave.
3. Make sure you understand what kind of report is to be prepared and due submission of record is next lab class.
4. Do sample calculations and some preliminary work to verify that the experiment was successful

MAKE-UPS AND LATE WORK

Students must participate in all laboratory exercises as scheduled. They must obtain permission from the faculty member for absence, which would be granted only under justifiable circumstances. In such an event, a student must make arrangements for a make-up laboratory, which will be scheduled when the time is available after completing one cycle. Late submission will be awarded less mark for record and internals and zero in worst cases.

LABORATORY POLICIES

1. Food, beverages & mobile phones are not allowed in the laboratory at any time.
2. Do not sit or place anything on instrument benches.
3. Organizing laboratory experiments requires the help of laboratory technicians and staff. Be punctual.

INDEX

EXP NO	EXPERIMENT NAME	PAGE NO
1	STRAIN GAUGE CHARACTERISTICS	11
2	LOAD CELL CHARACTERISTICS	16
3	LVDT CHARACTERISTICS	20
4	CHARACTERISTICS OF THERMOCOUPLES	26
5	LDR CHARACTERISTICS	29
6	CAPACITIVE TRANSDUCER CHARACTERISTICS	32
7	AD590 CHARACTERISTICS	35
8	STUDY OF PLC	39
9	IMPLEMENTATION OF LOGIC GATES USING PLC	44
10	IMPLEMENTATION OF TIMERS AND FLIP-FLOPS USING PLC	51
11	WATER LEVEL CONTROL USING PLC – SIMULATION	53
12	STEPPER MOTOR CONTROL USING PLC	55
ADDITIONAL/ADVANCED EXPERIMENTS		
13	CONVEYOR SYSTEM USING PLC	58
14	COMBINATION OF LOGIC GATES USING PLC	60

VERIFICATION BY HOD

INTERNAL EXAMINER

EXTERNAL EXAMINER

EXPERIMENT NO: 1

STRAIN GAUGE CHARACTERISTICS

AIM:

To study the characteristics of Strain gauge

APPARATUS REQUIRED:

Strain Measurement Trainer

THEORY:

When a material is subjected to any external load, there will be small change in the mechanical properties of the material. The mechanical property may be, change in the thickness of the material or change in the length depending on the nature of load applied to the material. This change in mechanical properties will remain till the load is released. The change in the property is called strain

in the material or the material get strained. So the material is mechanically strained, this strain is defined as ' The ratio between change in the mechanical property to the original property'. Suppose a beam of length L is subjected to a tensile load of P Kg the material gets elongated by a length of Δl So according to the definition strain S is given by

$$S = \Delta l / L \dots\dots\dots \text{Eq 1}$$

Since the change in the length of the material is very small it is difficult to measure Δl . So the strain is always read in terms of microstrain. Since it is difficult to measure the length Resistance strain gauges are used to measure strain in the material directly. Strain gauges are bonded directly on the material using special adhesives. As the material get strained due to load applied, the resistance of the strain gauge changes proportional to the load applied. This change in resistance is used to convert mechanical property in to electrical signal which can be easily measured and stored for analysis. The change in the resistance of the strain gauge depends on the sensitivity of the strain gauge. The sensitivity of strain gauges is usually expressed in terms of a gauge factor S_g where S_g is given as

$$\Delta R / R = S_g \dots\dots\dots \text{Eq 2}$$

Where ϵ is Strain in the direction of the gauge length. The output $\Delta R / R$ of a strain gauge is usually converter in to voltage signal with a Whetstones bridge, If a single gauge is used in one arm of whetstones bridge and equal but fixed resistors is used in the other arms, the output voltage is

$$E_o = E_i / 4 (\Delta R_g / R_g) \dots\dots \text{Eq 3}$$

Substituting Eq 2 into Eq 3 gives

$$E_o = 1/4 (E_i S_g \epsilon) \dots\dots \text{Eq 4}$$

The input voltage is controlled by the gauge size (the power it can dissipate) and the initial resistance of the gauge. As a result, the output voltage E_o usually ranges between 1 to 10 μV / microunits of strain.

SPECIFICATIONS:

DISPLAY RANGE : 3 1/2 digit RED LED display of 200 mV FSD to readup to +/-1999 microstrain .

GAUGE FACTOR SETTING : 2.1

BALANCE : Potentiometer to set zero on the panel.

BRIDGE EXCITATION : 10V DC

BRIDGE CONFIGURATIONS : Full Bridge.

MAX. LOAD : 1Kg.

POWER : 230 V +/- 10% at 50Hz. with perfect grounding.

All specifications nominal or typical at 230 C unless noted.

CANTILEVER BEAM SPECIFICATION

MATERIAL : Stainless Steel

BEAM THICKNESS (t) : 0.25 Cm.

BEAM WIDTH (b) : 2.8 Cms.

BEAM LENGTH (Actual) : 22 Cms.

YOUNGS MODULUS ($\square\square$) : 2×10^6 Kg / cm².

STRAIN GAUGE : Foil type gauge

GAUGE LENGTH (l) : 5 mm

GAUGE RESISTANCE (R) : 300 Ohms.

GAUGE FACTOR (g) : 2.01

CANTLIVER BEAM SETUP

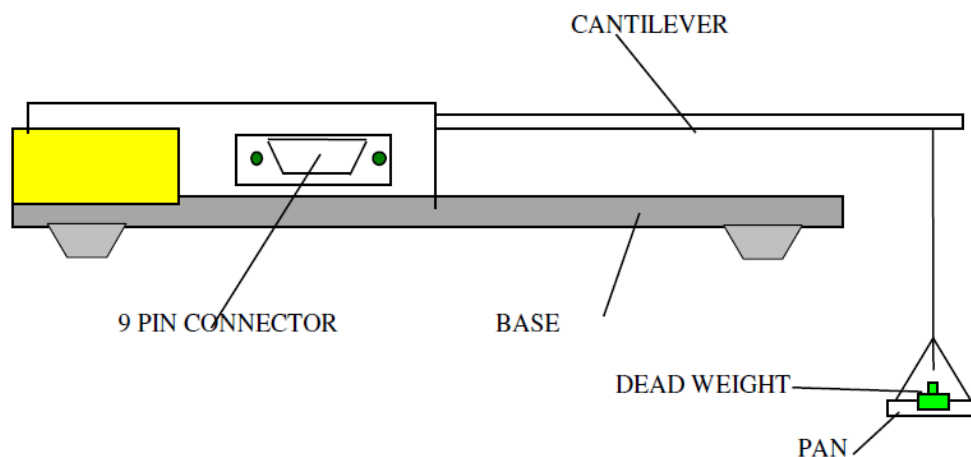

PHYSICAL DIMENSIONS

Over all BEAM Length (X) : 300 mm

Actual Length (L) : 220.0 mm (Middle of the Strain Gauge Grid to loading point)

Width of the Beam (b) : 28.0 mm

Thickness of the Beam (t) : 2.5 mm

PROCEDURE

- Check connection made and Switch ON the instrument by toggle switch at the back of the box. The display glows to indicate the instrument is ON.
- Allow the instrument in ON Position for 10 minutes for initial warm-up.
- Adjust the ZERO Potentiometer on the panel till the display reads '000'.
- Apply 1 Kg load on the cantilever beam and adjust the CAL potentiometer till the display reads 377 micro strain. (as per calculations given below) Remove the weights the display should come to ZERO in case of any variation adjust the ZERO pot again and repeat the procedure again. Now the Instrument is calibrated to read micro-strain.
- Apply load on the sensor using the loading arrangement provided in steps of 100g upto 1Kg.
- The instrument displays exact microstrain strained by the cantilever beam
- Note down the readings in the tabular column. Percentage error in the readings, Hysteresis and Accuracy of the instrument can be calculated by comparing with the theoretical values.

CONNECTION DETAILS

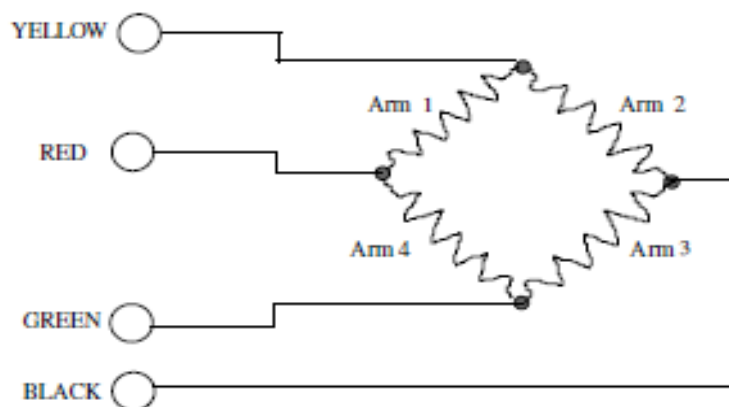

Specimen calculation for cantilever beam

$$S = (6 P L) / BT^2E$$

- P = Load applied in Kg. (1 Kg)
- L = Effective length of the beam in Cms. (22 Cms)
- B = Width of the beam (2.8 Cms)
- T = Thickness of the beam (0.25Cm)
- E = Youngs modulus (2 X 10⁶)
- S = Microstrain

Then the microstrain for the above can be calculated as fallows

$$S = \frac{6 \times 1 \times 22}{2.8 \times 0.25^2 \times (2 \times 10^6)}$$

$$S = 3.77 \times 10^{-4}$$

$$S = 377 \text{ microstrain.}$$

TABULAR COLUMN

S.NO	Weight	Actual readings (using formulae) S =(6PL)/BT ² E	Indicator readings (in micro strains)	ERROR in %	OUTPUT VOLTAGE (IN mV)
1					
2					
3					
4					
5					
6					
7					
8					
9					
10					

$$\% \text{ ERROR} = \frac{[(\text{Actual Reading (C)} - \text{Indicator Readings (D)})] \times 100}{\text{Max. Weight in gms}}$$

GRAPH

RESULT AND DISCUSSION

EXPERIMENT NO: 2

LOAD CELL CHARACTERISTICS

AIM:

To study the characteristics of load cell.

APPARATUS REQUIRED:

Load Measurement Trainer

THEORY:

The elastic members used in load cells are links, beams, rings and shear webs. Strain gauges are bonded on the fabricated specimen and the compression or tension load is applied to the specimen the material gets elongated or compressed due to the force applied. i.e. the material get strained. The strain incurred by the specimen depends on the material used and its elastic module. This strain is transferred to the strain gauges bonded on the material resulting in change in the resistance of the gauge. Since the strain gauges are connected in the form of Wheatstone's bridge any change in the resistance will imbalance the bridge. The imbalance in the bridge will intern gives out the output in mV proportional to the change in the resistance of the strain gauge.

CIRCUIT EXPLANATION

The circuit comprises of three parts:

1. Power Supply
2. Signal Conditioning And Amplifying
3. Analog To Digital Converter

1. POWER SUPPLY:

Inbuilt power supply use power to all electronic devices inside the circuitry. High stableregulated Power supply is used for better performance.

There are two different power supply inside the unit.

+12 - 0 - -12 V 500mA to drive digital integrated circuitry.

+5 - 0 - -5 V 250mA to drive A to D converter.

2. SIGNAL CONDITIONING AND AMPLIFYING.

Signal conditioner will process the output of transducer and presents a linear DC Voltage to the amplifier. This circuit will also buffers the inputs signal given to the differential amplifier. The operational amplifier is used as a differential amplifier where the signal gets amplified to required level. The amplifier gives out the analog output. This output is controlled and calibrated to get the linear to microstrain. This analog output is fad to the A to D converter.

3. ANALOG TO DIGITAL CONVERTER.

The output from the amplifier is a linearised analog DC voltage. This analog output is converted into digital output with the help of IC 7107 3.5 digit 200mV A to D converter. Then it is displayed through seven segmented LEDs.

SPECIFICATION:

MEASUREMENT OF LOAD

LOAD CELL :

SENSOR	: straingauges bonded on steel member for load measurement.
TYPE	: Compression.
STRAIN GAUGE RESISTANCE	: 350 ohms \pm 2%
MAX. LOADING	: 1 Kg.
CONNECTION	: Through four core shielded cable attached to the load cell.
EXCITATION	: 10V DC
ACCURACY	: 1%
LINEARITY	: 1%
MAX. OVER LOAD	: 125 %

INDICATOR :

DISPLAY	: 3.5 digit seven segment LED display is used for the indicator
EXCITATION	: 10 V DC
ACCURACY	: 1%
TARE	: Front panel Zero adjustment through Potentiometer.
CALIBRATION	: 1.00 Kg Load.
POWER SUPPLY	: 230 V +/- 10% 50 Hz.

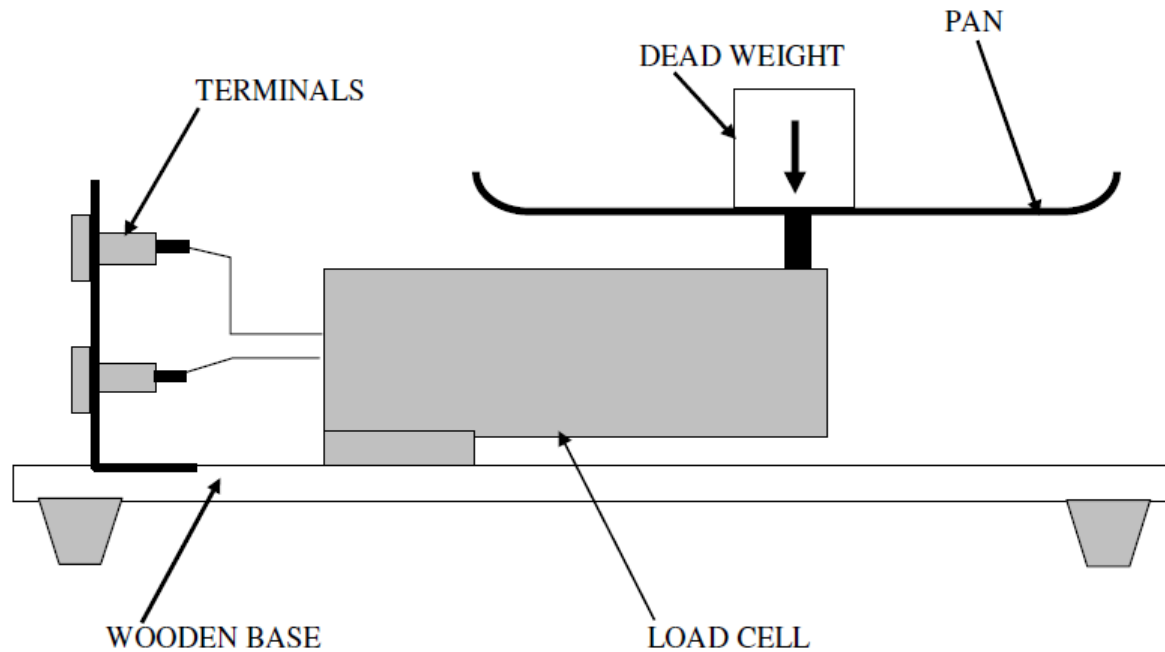

BEAM TYPE LOAD CELL MOUNTED ON A WOODEN BASE

CONNECTION DETAILS

POWER : 3 pin mains cable is provided with the instrument. Connect the 3 pin socket to the instrument at the rear panel and to the AC mains 230v supply.

SENSOR : Connect the four core cable attached to the load cell to the Bridge shown on the front panel. Match the colors of the wires with the connectors on the instrument panel.

PROCEDURE

- Check connection made and Switch ON the instrument by rocker switch at the front panel. The display glows to indicate the instrument is ON.
- Allow the instrument in ON Position for 10 minutes for initial warm-up.
- Adjust the Potentiometer in the front panel till the display reads “000”
- Apply load on the sensor using the loading arrangement provided.
- The instrument reads the load on the sensor and displays through LED. Readings can be tabulated and % error of the instrument, linearity, Hysteresis can be calculated.

TABULAR COLUMN

SL. NO.	ACTUAL LOAD in Kgms	INDICATOR LOAD In Kgms	ERROR in %	OUTPUT VOLTAGE (in mV)
1				
2				
3				
4				
5				
6				
7				
8				
9				
10				

$$\% \text{ Error} = \frac{(\text{Column No. 2} - \text{Column No.3}) \times 100}{\text{Max. Load}}$$

GRAPH

RESULT AND DISCUSSION

EXPERIMENT NO: 3

LVDT CHARACTERISTICS

AIM:

To study the characteristics of LVDT

APPARATUS REQUIRED:

LVDT Measurement Trainer

THEORY:

MEASUREMENT OF DISPLACEMENT

Differential transformers, based on a variable Inductance principle, are also used to measure displacement. The most popular variable-inductance transducer for linear displacement measurement is the Linear Variable Differential Transformer (LVDT). The LVDT illustrated in the fig. consists of three symmetrically spaced coils wound onto an insulated bobbin. A magnetic core, which moves through the bobbin without contact, provides a path for magnetic flux linkage between coils. The position of the magnetic core controls the mutual between the center or primary coil and with the two outside or secondary coils.

When an AC carrier excitation is applied to the primary coil, voltages are induced in the two secondary coils that are wired in a series-opposing circuit. When the core is centered between the two secondary coils, the voltage induced between the secondary coils are equal but out of phase by 180°. The voltage in the two coils cancels and the output voltage will be zero. When the core moves from the center position, an imbalance in mutual inductance between the primary coil and the secondary coil occurs and an output voltage develops. The output voltage is a linear function of the core position as long as the motion of the core is within the operating range of the LVDT.

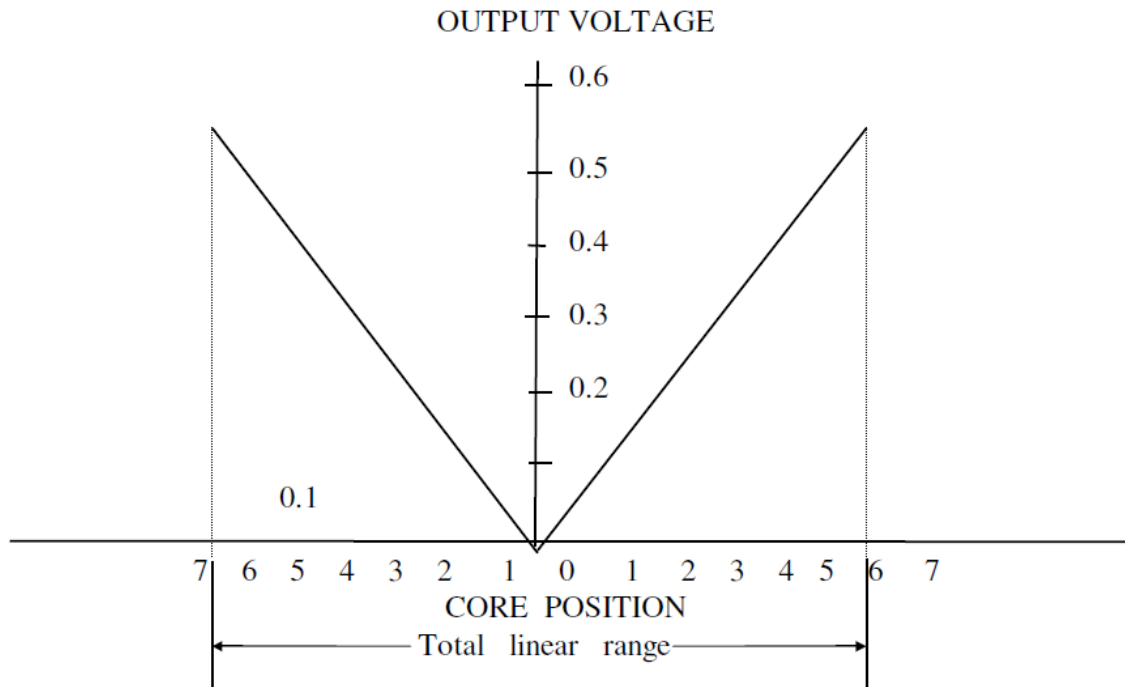

FIG. 1 Magnitude of the output Voltage as a function of LVDT core Position.

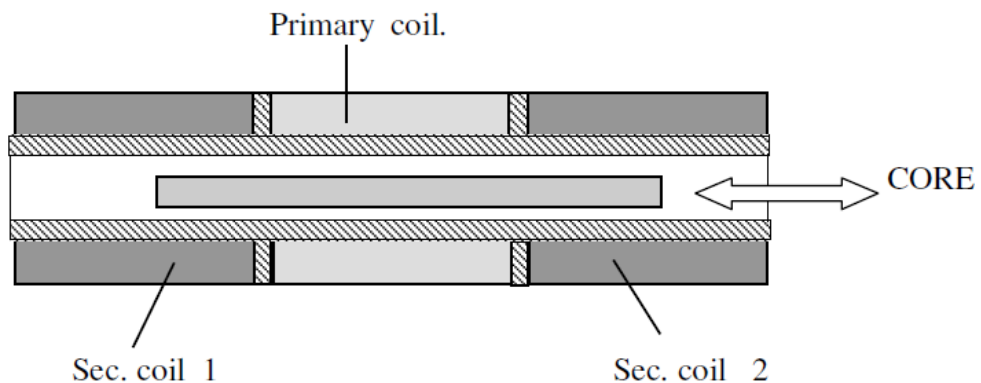

FIG. 2 Diagram to shows schematically the working of LVDT.

CIRCUIT EXPLANATION

The circuit can be divided into three parts.

1. Power supply.
2. Display.
3. Frequency generator & Signal Conditioner.

1. POWER SUPPLY.

The power supply unit provides power for all the electronic device in the instrument. There are two different regulated power supply in the unit.

- a) +5V, -5V 250mA too drive digital integrated circuits.

b) +5V - 0 -5V, 250mA to drive linear integrated circuits.

2. DISPLAY

The display circuit is basically a 3 1/2 digit voltmeter which accepts DC of 200mV for full scale Reading. The display will be indicated through seven segment bright LED's.

3. FREQUENCY GENERATOR

The circuit is an IC based (OP AMP) used to generate excitation voltage to the LVDT primary coil.

The IC's use +5 V and -5 V and produce a fine square wave of desired frequency. The Voltage can

be adjusted using a trimpot. The square wave is then trimmed by FET, PnP and NpN transistor. Then the Frequency is adjusted by varying the trimpot. The voltage and frequency is adjusted to 2khz 2 V which is fed to LVDT as an excitation voltage.

4. SIGNAL CONDITIONER

The circuit which processes the output of transducers and presents a fixed DC voltage to the display constitute the Demodulator and amplifier. Demodulator is a phase sensitive detector and AC amplifier which gives out DC voltage which is amplified and fed to summing amplifiers. The output of the summing amplifier is fed to the display.

SPECIFICATION

INDICATOR

- * DISPLAY : 3 1/2 digit seven segment red LED display of range 200mV for full scale deflection. to read +/- 1999 counts.
- * EXCITATION VOLTAGE : 1000 Hz at 1V
- * OPERATING TEMPERATURE : +100 C to 550 C
- * ZERO ADJUSTMENT : Front panel through Potentiometer.
- * SENSITIVITY : 0.1mm
- * SYSTEM INACCURACY : 1%
- * REPEATABILITY : 1%
- * CONNECTION : Through 6 core shielded cable with Din connector.
- * FUSE : 250mA fast glow type.
- * POWER : 230 V +/- 10 %, 50 Hz.

SENSOR

- * RANGE : +/- 10.0 mm
- * EXCITATION VOLTAGE : 1 to 4 kHz at 1 to 4V
- * LINEARITY : 1%
- * OPERATING TEMPERATURE : +100 C to 550 C
- * CONNECTION : Through 6 core shielded cable provided along with the sensor of 2M length.
- * CALIBRATION JIG : Micrometer of 0 to 25mm length is mounted on the base.

PANEL DETAILS

DISPLAY : 3 1/2 Digit LED display of 200mV FSD to read upto “+/- 1999” counts.

ZERO : Single turn potentiometer to adjust “000” when the sensor is connected.

CAL : Single turn potentiometer to adjust the calibration point.

CIRCUITRY : Block diagram of the circuit for displacement indicator. The diagram also shows LVDT block diagram also.

LVDT WITH CALIBRATION JIG

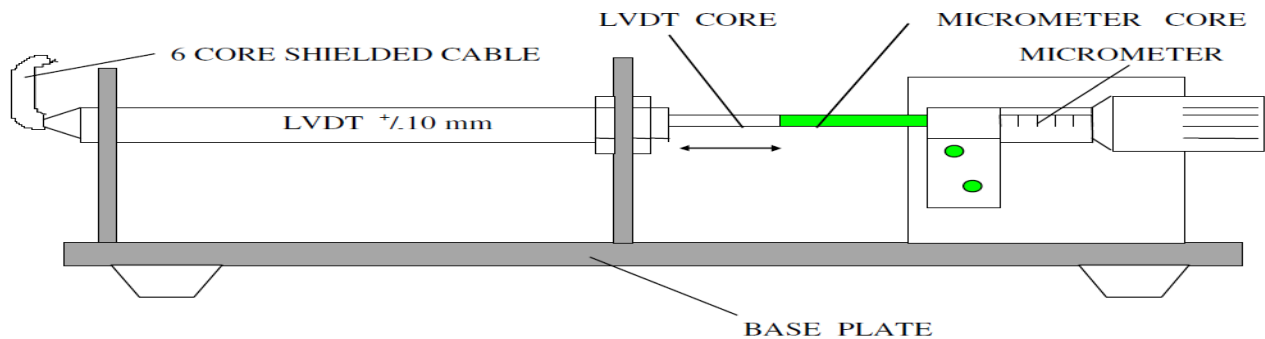

MOUNTING OF LVDT ON THE CALIBRATION JIG

LVDT has to be mounted perfectly on the calibration Jig. Micrometer should be moved till the micrometer reads 20.0 mm. LVDT should be mounted too to the center plate by the two nuts provided. The core of the LVDT should be aligned with the core of the micrometer. Adjust the core of the LVDT till it touches the micrometer core and tighten the nut.

CONNECTION DETAILS

Connecting instrument to mains

3 Pin power chord is provided, attached to the instrument. Connect the 3pin plug to 230V 50Hz. socket.

Before connecting ensure that the power On switch is in OFF position.

Sensor connection

6 core shielded cable is connected to the LVDT with male connectors of different colors are fixed to each wire. Connect the male pins to the socket matching the color correctly.

PROCEDURES

- 1 Connect the power supply chord at the rear panel to the 230V 50Hz supply. Switch on the instrument by pressing down the toggle switch. The display glows to indicate the instrument is ON.
- 2 Allow the instrument in ON position for 10 minutes for initial warm-up.
3. Rotate the micrometer till it reads “20.0”
- 3 Adjust the CAL potentiometer at the front panel so that the display reads “10.0”
- 4 Rotate the core of micrometer till the micrometer reads “10.0” and adjust the ZERO potentiometer till the display reads “00.0”
- 5 Rotate back the micrometer core upto 20.0 and adjust once again CAL Potentiometer till the display read 10.0. Now the instrument is calibrated for +/-10.0mm range. As the core of LVDT moves the display reads the displacement in mm.
6. Rotate the core of the micrometer in steps of 1 or 2 mm and tabulate the readings. The micrometer will show the exact displacement given to the LVDT core the display will read the displacement sensed by the LVDT. Tabulate the readings and Plot the graph Actual V/s indicator reading.

TABULAR COLUMN

SL. No.	ACTUAL MICROMETER READINGS (MM)	INDICATOR READINGS LVDT (MM)	%ERROR	OUTPUT VOLTAGE (in mV)

GRAPH:

RESULT

EXPERIMENT NO: 4 CHARACTERISTICS OF THERMOCOUPLES

AIM

To study the characteristics of thermocouple

APPARATUS

Thermocouple trainer

THEORY

When two dissimilar materials are brought into contact, a potential develops as a result of an effect known as the “Seeback effect”. A Thermocouple is a very simple temperature sensor operates based on the Seeback effect, which results in the generation of a thermoelectric potential when two dissimilar metal are joined together to a junction. The electric potential of the material accepting electrons becomes negative at the interface, while the potential of the material providing the electrons become positive. Thus an electric field is established by the flow of electrons across the interface. When this electric field becomes sufficient to balance the diffusion forces, a state of equilibrium with respect to electron migration is established. Since the magnitude of the diffusion force is controlled by the temperature of the thermocouple junction, the electric potential developed at the junction provides a measure of the temperature.

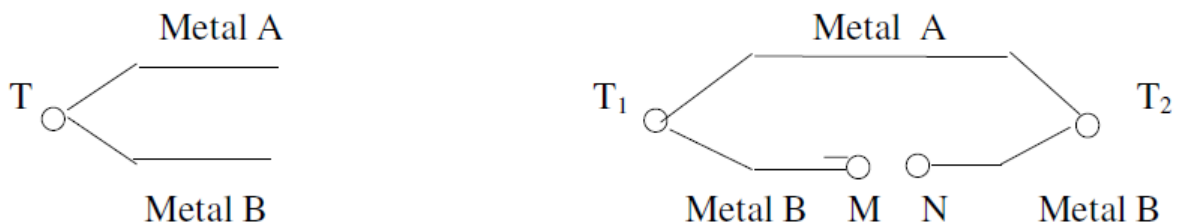

The electric potential is usually measured by introducing a special junction in an electric circuit. The voltage across terminals M - N can be represented approximately by an empirical equation having the form,

$$E_0 = C_1 (T_1 - T_2) + C_2 (T_1^2 - T_2^2)$$

When C1 and C2 are thermoelectric constants that depend on the material used to form the junctions. T1 and T2 are junction temperature.

CIRCUIT EXPLANATION

The circuit comprises of three parts :

1. POWER SUPPLY
2. SIGNAL CONDITIONING AND AMPLIFYING

3. ANALOG TO DIGITAL CONVERTER

1. POWER SUPPLY:

Inbuilt power supply use power to all electronic devices inside the circuitry. High stable regulated Power supply is used for better performance. There are two different power supply inside the unit. +5 - 0 - -5 V 5000mA for Analog and Digital circuits and also for sensor excitation

2. SIGNAL CONDITIONING AND AMPLIFYING.

The circuitry comprises of signal conditioner and amplifier. The output of the sensor is amplified to required level. The Thermocouple gives out directly which is amplified. Thermistor and RTD are connected to the ground through a resistor, and the voltage is applied to the other end of the sensor. The resistance change in the sensor will gives the mV out put which is amplified and controlled. Analog out put is fad to the ADC.

3. ANALOG TO DIGITAL CONVERTER.

The output from the amplifier is a linearised analog DC voltage. This analog output is converted into digital output with the help of IC 7107 3.5 digit 200mA A to D converter. Then it is displayed through seven segmented LEDs.

SPECIFICATION

SENSOR : J- type Thermocouple (Fe-K)

DISPLAY : 3 1/2 Digit LED Display. 200mV FSD to read upto +/-1999 count

INITIAL &FINAL SET : Through single turn Potentiometer.

TEMPERATURE : 1000 C

TEMP. SOURCE : Water kettle.

TEMP. MASTER : Glass bead Thermometer.

PANEL DETAILS

DISPLAY : 3 1/2 Digit LED Display of 200 mV FSD

INITIAL SET: Single turn potentiometer to set Initial Temperature (Room Temperature)

FINAL SET :Single turn potentiometer to Calibrate the instrument (Max. Temperature)

POWER ON : Rocker switch to control power supply to the instrument.

CONNECTION DETAILS

POWER : 3 pin mains cable is provided with the instrument. Connect the 3 pin socket to the instrument at the rear panel and to the AC mains 230v supply.

: Connect the kettle to 230 V supply with the cable supplied.

NOTE : Before connecting ensure the voltage is 230 V and the Power switch is in off position).

SENSORS : Connect Thermocouple to the connector on the rear panel.

PROCEDURE

* Check connection made and Switch ON the instrument by rocker switch at the front panel. The display glows to indicate the instrument is ON.

* Allow the instrument in ON Position for 10 minutes for initial warm-up.

- * Pore around 3/4th full of water to the kettle and place sensors and thermometer inside the kettle
- * Note down the Initial water temperature from the thermometer.
- * Adjust the Initial set Potentiometer in the front panel till the display reads initial water temperature.
- * Switch on the kettle and wait till the water boils note down the reading inn the thermometer and set Final set potentiometer till the display reads boiling water temperature.
- * Remove the sensor from the boiling water immerse it in the cold water. Set the cold water temperature using initial set potentiometer.
- * Repeat the process till the display reads exact boiling water and cold-water temperature. Change the water in the kettle with and re heat the water. Now the display starts showing exact temperature raises in the kettle.
- * Note down the readings for every 100 C rise in temperature and tabulate the readings in the tabular column for Indicator reading and thermometer reading.

SL NO.	THERMOMETER READING	THERMOCOUPLE	ERROR	PERCENTAGE ERROR	OUTPUT VOLTAGE (mV)

$$\text{PERCENTAGE ERROR} = \frac{(\text{ACTUAL READING} - \text{INDICATED READING})}{\text{MAXIMUM TEMPRATURE}} * 100$$

GRAPH:

RESULT:

EXPERIMENT NO: 5

LDR CHARACTERISTICS

AIM:

To study the characteristics of LDR.

APPARATUS REQUIRED:

Light dependent resistor measurement trainer.

THEORY

Light dependent resistor is a semiconductor material changes its resistance property when exposed to light. The resistance of the LDR will be maximum when it is in dark, and reduces as it get exposed to light. The variation of the resistance is proportional to the intensity of the light. Because of this property LDR finds wide applications like, finding light intensity, used as electronic eye in clocks, used in control applications in solar lights, used in street light to switch on and switch off automatically and many other applications.

LDR trainer is an experimental setup to study the characteristics of LDR and its behavior with respect to light intensity. LDR is fixed to movable rod inside a metal tube where a bulb is fixed at the other end. The intensity of the light can be varied by varying the excitation voltage to the bulb and also by moving the LDR near and away from the bulb. The whole setup is mounted on a base where the experiment can be conducted. As a study project the indicator is settable to display the distance moved by the LDR with respect to the light source. The electronic part of the setup comprises of a simple resistance to voltage converter circuit where the operational amplifier is used for processing. LDR is connected through a resistor to a voltage source Vcc, and the other end to the +ve input pin of the amplifier. The -ve input pin of the amplifier is connected to millivolt feeding source to adjust the display to read zero through a variable potentiometer. The input signal is amplified and fed to display unit. Variable Power supply is provided to vary the light intensity.

CIRCUIT EXPLANATION:

The circuit comprises of three parts:

1. POWER SUPPLY
2. SIGNAL CONDITIONING AND AMPLIFYING
3. ANALOG TO DIGITAL CONVERTER

1. POWER SUPPLY:

Inbuilt power supply use power to all electronic devises inside the circuitry. High stable regulated Power supply is used for better performance.

There are three different power supply inside the unit.

+12 - 0 - -12 V 500mA to drive digital integrated circuitry.

+5 - 0 - -5 V 250mA to drive A to D converter.

1.2 - 05 V 200mA variable Supply for bulb

2. SIGNAL CONDITIONING AND AMPLIFYING.

Voltage is given to the LDR with the other side grounded with resistor. The center point is connected as input to the operational amplifier. As the resistance changes in the LDR will change the voltage to the input which is amplified to required level. This output is controlled and fed to the A to D converter.

3. ANALOG TO DIGITAL CONVERTER.

The output from the amplifier is a linearised analog DC voltage. This analog output is converted into digital output with the help of IC 7107 3.5 digit 200mA A to D converter. Then it is displayed through seven segmented LEDs.

4. VARIABLE POWER SUPPLY

Variable power supply is provided which varies voltage from 1 V to 05 V. This VPS is given to Bulb where the intensity of the light can be controlled.

CONNECTION DETAILS

POWER : Connect the 3-pin power cable attached to the instrument to the AC mains 230 V 50Hz supply.

NOTE : Before connecting ensure the voltage is 230 V and the Power switch is in OFF position).

LDR : Connect LDR between **Yellow and Green** terminals mentioned LDR. Connect the bulb between **Red and Black** mentioned variable power supply.

PROCEDURE:

- * Check connection made and Switch ON the instrument by rocker switch at the front panel. The display glows to indicate the instrument is ON.
- * Allow the instrument in ON Position for 10 minutes for initial warm-up.
- * Push the LDR shaft full inside till the mark on the shaft coincides the ZERO on the scale.
- * Increase the voltage to the bulb by adjusting VPS potentiometer.
- * Adjust the ZERO Potentiometer till the display reads "000"
- * Pull LDR slowly outside for max.displacement value and adjust VPS potentiometer till the display reads exact distance moved.
- * Push the LDR inside so that mark coincides zero position and adjust the ZERO potentiometer till the display reads zero once again.
- * Pull the LDR slowly in step of 5 or 10mm and note down the corresponding display readings for the distance moved.
- * Plot the graph distance moved versus display reading.
- * Set the voltage VPS is 3V in calibration

SL NO.	ACTUAL DISPLACEMENT	INDICATED READING	ERROR	OUTPUT VOLTAGE

GRAPH:

RESULT

EXPERIMENT NO: 6

CAPACITIVE TRANSDUCER CHARACTERISTICS

AIM:

To study the characteristics of Capacitive Transducer.

APPARATUS:

Capacitance Measurement Trainer Linear Type.

THEORY:

The capacitivetransducer consist of two plates (A1), one fixed to the base and the other moving over the fixed plate parallel with a small gap between the two. The over lapping of the plate will act as a capacitor with air as dielectric media. The parallel plate capacitor is used as a displacement sensor, which measure the displacement. The other Capacitance transducer is used for measurement of angular displacement. Gang condenser is used to measure the angular displacement. Here the thin aluminum plates are fixed to one pole between these plate thin aluminum plates of same dimension overlap as the other pole on which the plates are mounted. This will induce the capacitance between the plates which varies based on the area of overlapping of the plates. The instrument is built around an NE556 integrated circuit. The NE556 is a dual 556 times IC. The first timer is connected as a stable multi vibrator while the second time is used as a mono stable.

At each trigger, the mono stable output a pulse whose width is determined by the Resistance and the Capacitance of the parallel plate capacitor C_x connected across the measuring terminals. Specifically, the mono stable duration is given by $T=1.1 R \text{ range} \times C_x$, where R range is the range resistance and capacitance across the measurement terminals. From this is is seen that the width of the mono stable pulse is directly proportional to capacitance C_x (parallel plate capacitor). Since the mono stable duration is itself is proportional to capacitance C_x (parallel plate capacitor) across the measurement terminals, it follows that the meter indication is directly proportional to the capacitance. The mono stable output is averaged using averaging circuit and feed to amplifier for Zero setting and calibration the instrument to read displacement.

BLOCK DIAGRAM OF ELECTRONIC CAPACITANCE METER

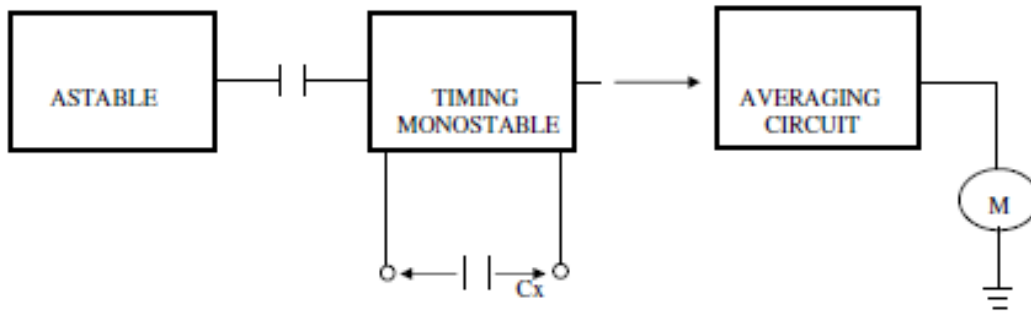

WAVEFORM SKETCHES FOR CAPACITANCE MEASUREMENT

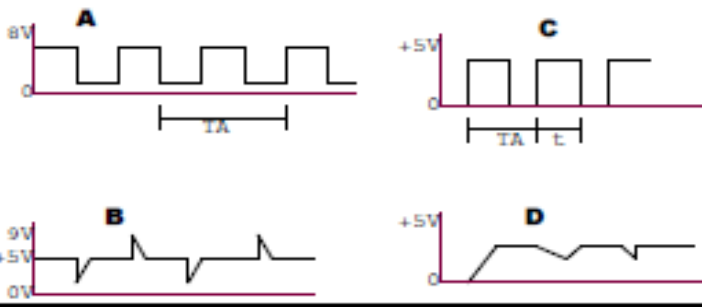
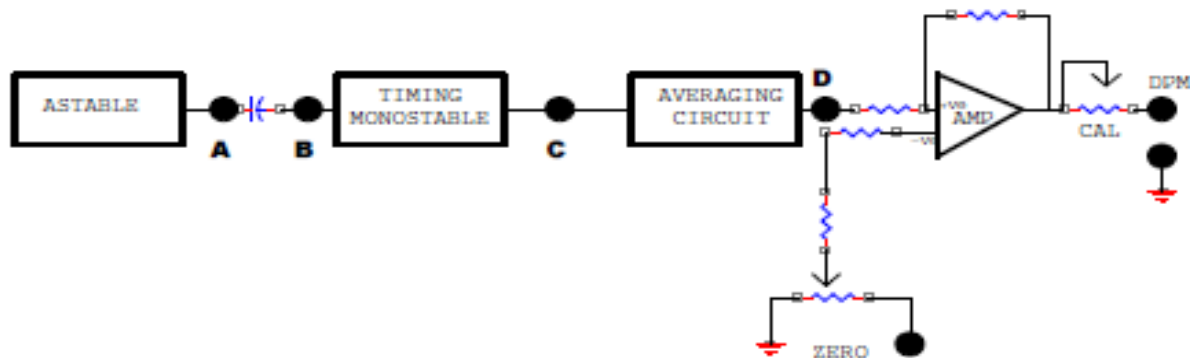

SPECIFICATION

- Sensor : Parallel Plate capacitance.
- Sensor Material : Aluminum plates
- Dielectric Medium : Air
- 1. Displacement : 0-50 mm
- Accuracy : 5 to 10%
- Display : 3.5 digit LED display to read +/- 1999 counts for +/- 200 mv FSD
- Power : 230V +/- 10% 50 HZ

OPERATING PROCEDURE

- Check connection made to the instrument
- Allow the instrument in ON position for 10 minits for initial warm-up.
- Move the moving plate to Zero position.
- Adjust the ZERO potentiometer so that the display reads '000'.
- Move the plate in step of 10 mm and note down the reading in the tabular column till 50 mm
- While taking readings wait for some time to get the display stabilized and then take the
- readings

SL NO.	ACTUAL SCALE READINGS	INDICATED CAPACITANCE READINGS	ERROR	PERCENTAGE ERROR	OUTPUT VOLTAGE

GRAPH:

RESULT

EXPERIMENT NO: 7 CHARACTERISTICS OF AD590 THERMISTOR

AIM

To study the characteristics of thermocouple

APPARATUS

AD 590 trainer

THEORY

A **thermistor** is a type of resistor whose resistance is dependent on temperature, more so than in standard resistors. The word is a portmanteau of *thermal* and *resistor*. Thermistors are widely used as inrush current limiter, temperature sensors (NTC type typically), self-resetting overcurrent protectors, and self-regulating heating elements.

Thermistors differ from resistance temperature detectors (RTDs) in that the material used in a thermistor is generally a ceramic or polymer, while RTDs use pure metals. The temperature response is also different; RTDs are useful over larger temperature ranges, while thermistors typically achieve a greater precision within a limited temperature range, typically $-90\text{ }^{\circ}\text{C}$ to $130\text{ }^{\circ}\text{C}$

Assuming, as a first-order approximation, that the relationship between resistance and temperature is linear, then:

$$\Delta R = k\Delta T$$

where

ΔR , change in resistance

ΔT , change in temperature

k , first-order temperature coefficient of resistance

Thermistors can be classified into two types, depending on the classification of k . If k is positive, the resistance increases with increasing temperature, and the device is called a positive temperature coefficient (**PTC**) thermistor, or **posistor**. If k is negative, the resistance decreases with increasing temperature, and the device is called a negative temperature coefficient (**NTC**) thermistor. Resistors that are not thermistors are designed to have a k as close to 0 as possible, so that their resistance remains nearly constant over a wide temperature range.

Instead of the temperature coefficient k , sometimes the *temperature coefficient of resistance* α_T (alpha sub T) is used. It is defined as

$$\alpha_T = \frac{1}{R(T)} \frac{dR}{dT}$$

This α_T coefficient should not be confused with the a parameter below.

CIRCUIT EXPLANATION

The circuit comprises of three parts :

1. POWER SUPPLY
2. SIGNAL CONDITIONING AND AMPLIFYING
3. ANALOG TO DIGITAL CONVERTER

1. POWER SUPPLY:

Inbuilt power supply use power to all electronic devices inside the circuitry. High stable regulated Power supply is used for better performance. There are two different power supply inside the unit. +5 - 0 - -5 V 5000mA for Analog and Digital circuits and also for sensor excitation

2. SIGNAL CONDITIONING AND AMPLIFYING.

The circuitry comprises of signal conditioner and amplifier. The output of the sensor is amplified to required level. The Thermocouple gives out directly which is amplified. Thermistor and RTD are connected to the ground through a resistor, and the voltage is applied to the other end of the sensor. The resistance change in the sensor will gives the mV output which is amplified and controlled. Analog out put is fad to the ADC.

3. ANALOG TO DIGITAL CONVERTER.

The output from the amplifier is a linearized analog DC voltage. This analog output is converted into digital output with the help of IC 7107 3.5 digit 200mA A to D converter. Then it is displayed through seven segmented LEDs.

SPECIFICATION

SENSOR : J- type Thermocouple (Fe-K)

DISPLAY : 3 1/2 Digit LED Display. 200mV FSD to read upto +/-1999 count

INITIAL & FINAL SET : Through single turn Potentiometer.

TEMPERATURE : 1000 C

TEMP. SOURCE : Water kettle.

TEMP. MASTER : Glass bead Thermometer.

PANEL DETAILS

DISPLAY : 3 1/2 Digit LED Display of 200 mV FSD

INITIAL SET: Single turn potentiometer to set Initial Temperature (Room Temperature)

FINAL SET :Single turn potentiometer to Calibrate the instrument (Max. Temperature)

POWER ON : Rocker switch to control power supply to the instrument.

CONNECTION DETAILS

POWER : 3 pin mains cable is provided with the instrument. Connect the 3 pin socket to the instrument at the rear panel and to the AC mains 230v supply.

: Connect the kettle to 230 V supply with the cable supplied.

NOTE : Before connecting ensure the voltage is 230 V and the Power switch is in off position).

SENSORS : Connect Thermocouple to the connector on the rear panel.

PROCEDURE

- * Check connection made and Switch ON the instrument by rocker switch at the front panel. The display glows to indicate the instrument is ON.
- * Allow the instrument in ON Position for 10 minutes for initial warm-up.
- * Pour around 3/4th full of water to the kettle and place sensors and thermometer inside the kettle
- * Note down the Initial water temperature from the thermometer.
- * Adjust the Initial set Potentiometer in the front panel till the display reads initial water temperature.
- * Switch on the kettle and wait till the water boils note down the reading in the thermometer and set Final set potentiometer till the display reads boiling water temperature.
- * Remove the sensor from the boiling water immerse it in the cold water. Set the cold water temperature using initial set potentiometer.
- * Repeat the process till the display reads exact boiling water and cold-water temperature. Change the water in the kettle with and re heat the water. Now the display starts showing exact temperature raises in the kettle.
- * Note down the readings for every 100 C rise in temperature. and tabulate the readings in the tabular column for Indicator reading and thermometer reading.

SI NO	ACTUAL READING	INDICATED READING	ERROR	% ERROR	OUTPUT VOLTAGE(mV)

GRAPH:

RESULT

EXPERIMENT NO: 8 STUDY OF PLC

AIM:

To have a basic overview on the PLC platform.

APPARATUS:

Sciencetech 2400I Universal PLC Platform.

THEORY

A Programmable Logic Controller (PLC) is an industrial computer control system that continuously monitors the state of input devices and makes decisions based upon a custom program to control the state of output devices. Almost any production line, machine function, or process can be greatly enhanced using this type of control system. However, the biggest benefit in using a PLC is the ability to change and replicate the operation or process while collecting and communicating vital information.

Another advantage of a PLC system is that it is modular. That is, you can mix and match the types of Input and Output devices to best suit your application

According to NEMA (National Electrical Manufacturer Association): “PLC is a digitally operated electronic system, designed especially for the use in industrial environment, which use programmable memory for internal storage of user oriented instructions for implementing specific function such as logic, sequencing, timing, counting & arithmetic to control, through digital & analog inputs & outputs for various types of machines & processes.” Both the PLC & its associated peripherals are designed so that they can be easily integrated into an industrial control system & easily used in all intended functions.

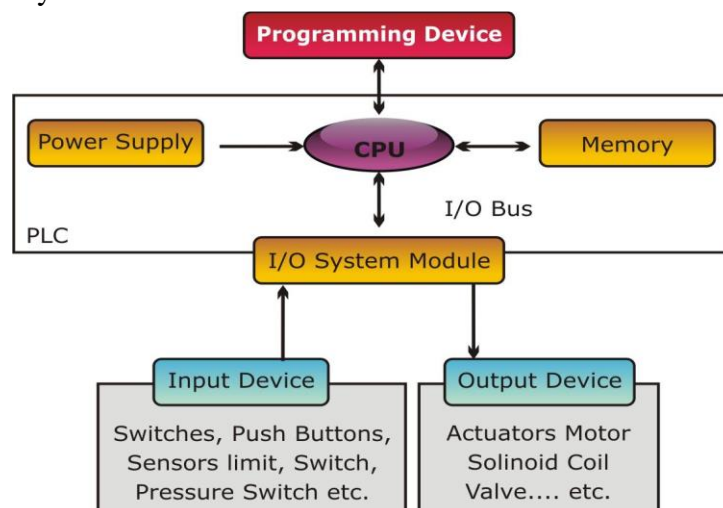
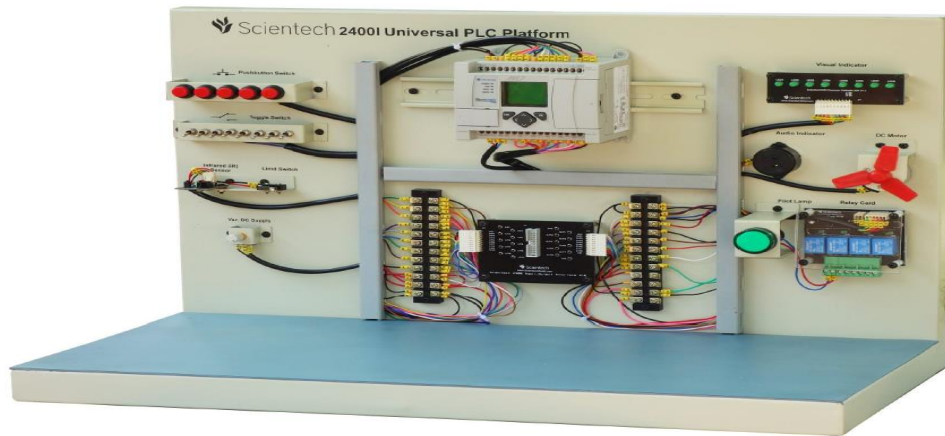

Fig: Functional Description of pl

MICROLOGIX 1100 CPU DESCRIPTION:

The MicroLogix 1100 programmable controller contains a power supply, input and output circuits, a processor, an isolated combination RS-232/485 communication port, and an Ethernet port. Each controller supports 18 I/O points (10 digital inputs, 2 analog inputs, and 6 discrete outputs).

Sciencetech 2400I Universal PLC Platform is an ideal setup to study the working of PLC's used for industrial applications



Sciencetech 2400I Universal PLC Platform

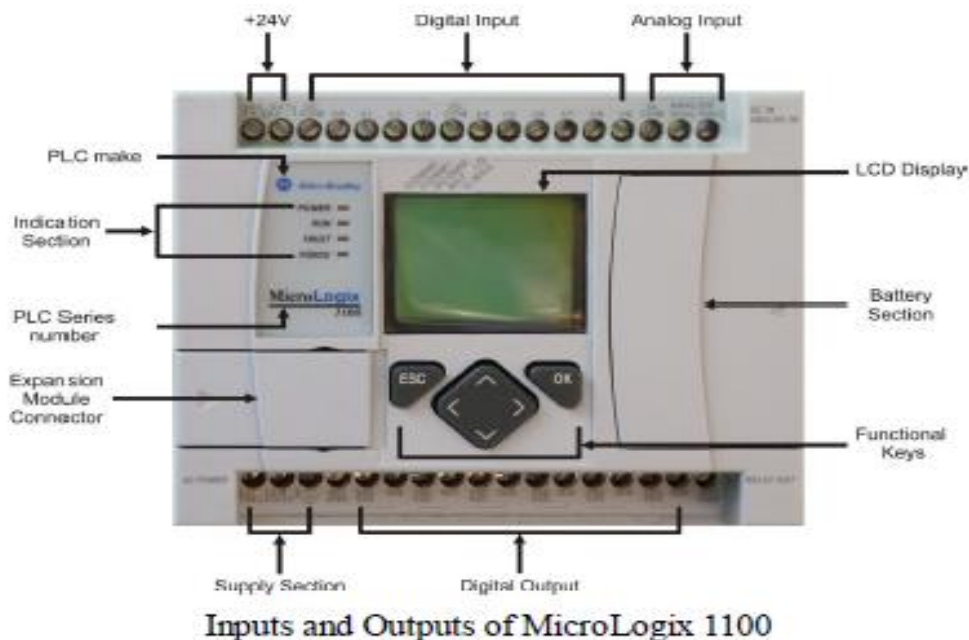

Technical Specifications

Model No.Scientech2400	I
Allen Bradley CPU Type	Micro Logic 1100 (1763-L16BWA)
Digital Input	10
Digital Output	6 (Relay)
Analog Input	2 (Voltage Input)
Expansion Module	Expandable
Potentiometer	1
Toggle Switches	8
Pushbutton switches	5
IR Sensor	1
Limit Switch	1
LED display	8
Buzzer	1
DC motor	1
Pilot Lamp	1
Relay Card (4 Relay)	1

Comprehensive :- Over 65 instructions including, simple bit, time and counter instructions, as well as instructions, for power full applications like sequence, highspeed counter, and shift registers.

Fast Execution time : 500-instruction program in only 1.56 ms.

Memory Size :10K words (approximatey737 instruction words,437 data-table words)

Timers/Counters, Max : 40 timers; 32 counters (fixed)

Program Scan Time/K word : 2 ms Typical

Interfacing : Ethernet

Input Voltage : 24VDC

Output Voltage : 5VDC

Analog Input Specifications

Specification	Value
Voltage Input Range	0...10.0V DC - 1 LSB
Type of Data	10-bit unsigned integer
Voltage Impedance	>199 k Ω
Input Resolution	10 bit
Non-linearity (in percent full scale)	$\pm 0.5\%$ of full scale
Overall Accuracy	$\pm 1.0\%$ of full scale
Update Time	100/20/16.67/4 ms (selectable)
Voltage Input Overvoltage Protection	10.5 V DC
Field Wiring to Logic Isolation	Non-isolated with internal logic

Input Output Addressing Details**Sciencetech 2400I Input Addressing Detail**

PLC Input Address	Component Detail
I1:0/0	Pushbutton Switch_1 (PB1)
I1:0/1	Pushbutton Switch_2 (PB2)
I1:0/2	Pushbutton Switch_3 (PB3)
I1:0/3	Toggle Switch_1 (TS1)
I1:0/4	Toggle Switch_2 (TS2)
I1:0/5	Toggle Switch_3 (TS3)
I1:0/6	Toggle Switch_4 (TS4)
I1:0/7	IR Sensor
I1:0/8	Limit Switch
IV0 (I:0.4)	Analog Input 1
IV1 (I:0.5)	Analog Input 2

Sciencetech 2400I Output Addressing Detail

PLC Output Address	Component Detail
O0:0/0	Buzzer
O0:0/1	LED1
O0:0/2	LED2
O0:0/3	LED3
O0:0/4	DC Motor
O0:0/5	Pilot Lamp & Relay_1

RESULT

EXPERIMENT NO: 9

IMPLEMENTATION OF LOGIC GATES USING PLC

AIM:

To implement logic gates using PLC.

APPARATUS:

- Sciencetech 2400I Universal PLC Platform
- Ethernet Cable
- Mains cord

Theory:

The majority of PLC manufacturers use the ladder logic diagram programming language to program their programmable logic controllers (PLCs). Some manufacturers prefer using logic gate circuits or Boolean expressions to program their PLCs. Therefore, it is beneficial to know how to convert one type of PLC programming language to the other.

NOT Gates or Inverters

The output of a *NOT gate* is the inverse of the input. The NOT gate is sometimes called an *inverter*. The function of a NOT gate is simulated by the electric circuit displayed in Figure(1). When the switch is closed, the electric bulb is short circuited, and it turns off. When the switch is open, electric current flows through the light bulb, and the light bulb turns on. Like the NOT gate, the output is on when the input is off and vice versa.

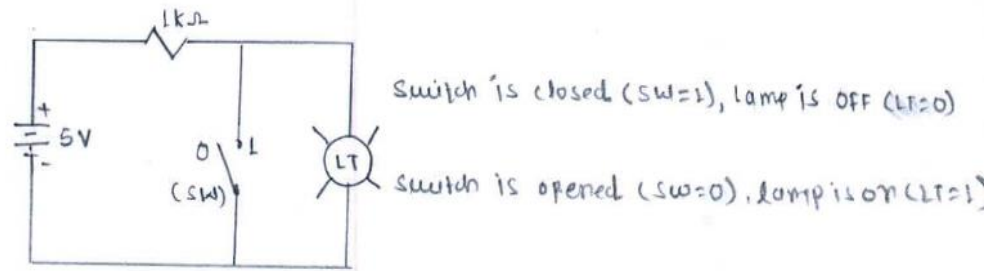

Figure: (1) Electric circuit emulating the function of a NOT gate.

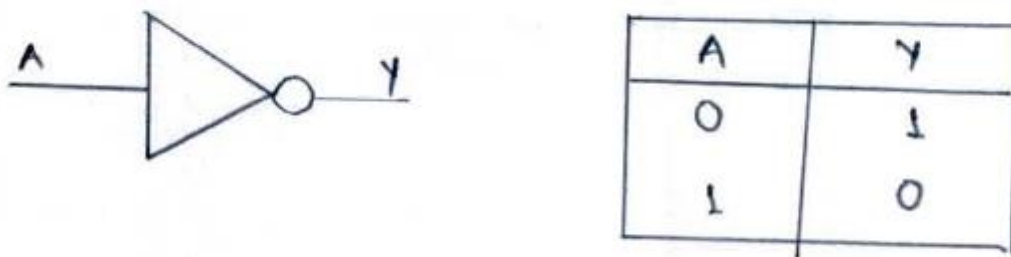

Figure:(2) Boolean expression, gate symbol & truth table.

AND Gates

The function of an AND gate is simulated in the electric circuit displayed in Figure (4). Notice that the lamp will be on only when both switches are closed. Figure (5) displays a two-input AND logic gate symbol, its Boolean expression, and its truth table. In the truth table, you can see that there is only one set of inputs that produces a logic high output.

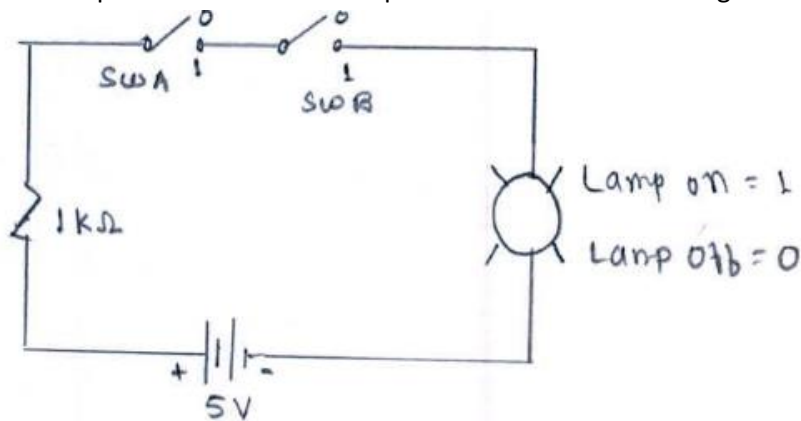

Figure:(4) Electric circuit emulating an AND gate

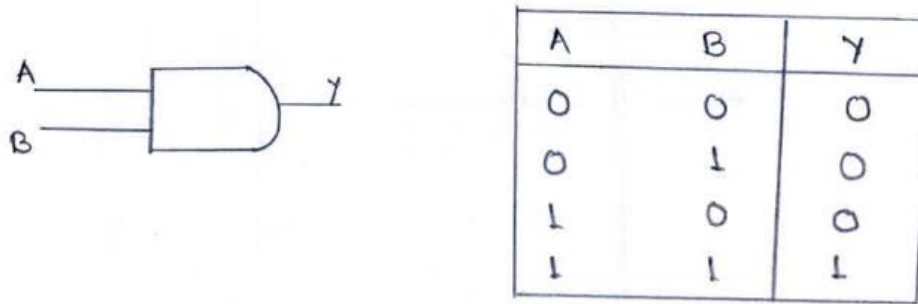

Figure: (5) Boolean expression, symbol, truth table for two input AND gate

OR Gates

The function of an *OR gate* is simulated in the electric circuit displayed in Figure (7). Notice that the lamp will be ON when one *or* both of the switches are closed. Figure (8) displays a two input OR logic gate symbol, its Boolean expression, and its truth table. The truth table shows a logic high output for all combinations of inputs except where both A and B are low. When either input A, B, or both are on, the output is on.

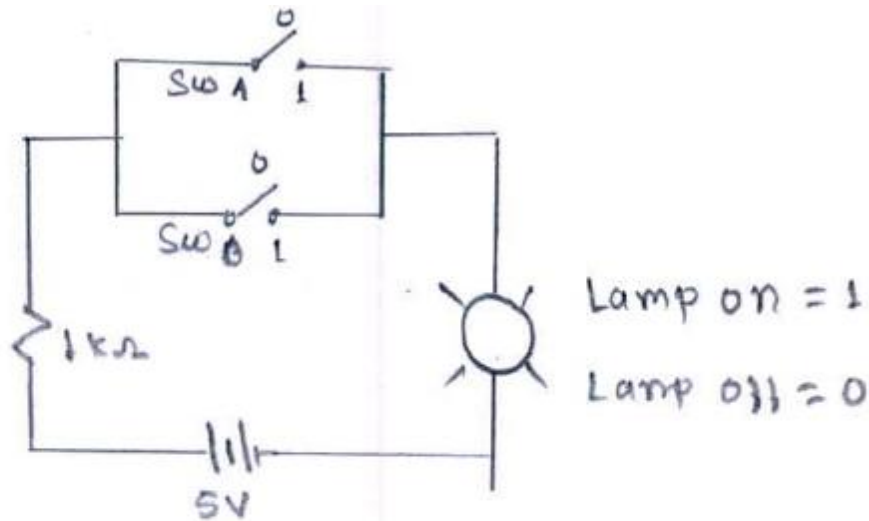

Figure:(7) Electric circuit emulation of OR gate

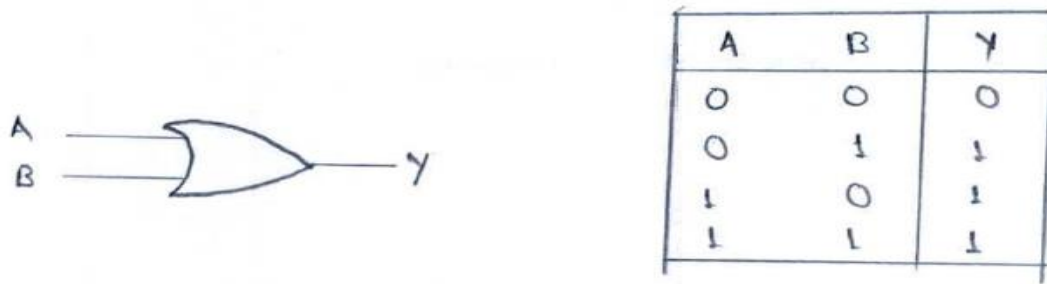

Figure:(8) Two input OR gate

NAND Gates

The function of a *NAND gate* is simulated in the electric circuit displayed in Figure (10). Notice that the lamp will be off when both switches are closed. The NAND gate takes its name from NOT and AND. Its outputs are the inverse of the AND gate. Figure (11) displays a two-input NAND logic gate symbol, its Boolean expression, and its truth table. Notice that the NAND gate can be built by connecting an AND gate in series with a NOT gate.

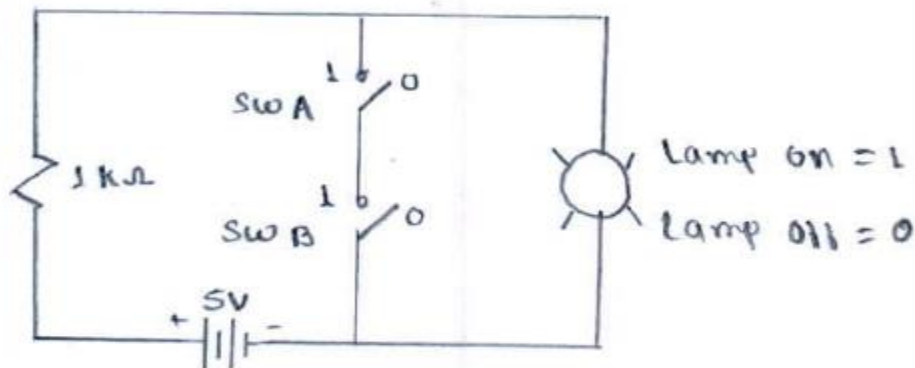

Figure:(10) Electric circuit emulating a NAND gate

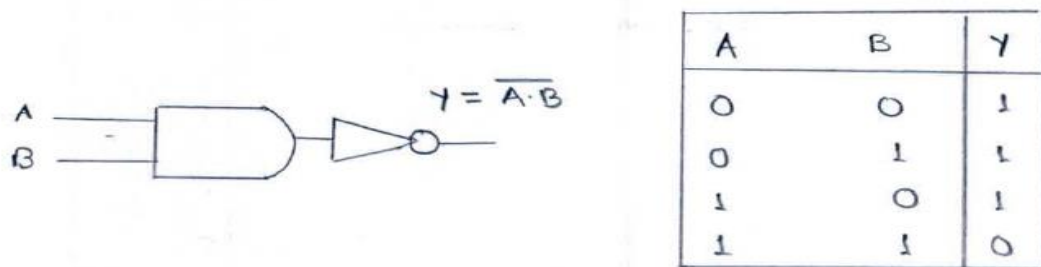

Figure:(11) Boolean expression, gate symbol & truth table for NAND gate

NOR Gates

The function of a NOR logic gate is simulated in the electric circuit displayed in Figure 13. Notice that the lamp will be ON when both switches are open. The *NOR gate* takes its name from NOT and OR. Its outputs are the inverse of the OR gate. Figure 18 displays a two-input NOR logic gate symbol, its Boolean expression, and its truth table. Notice the NOR gate can be built by connecting an OR gate in series with a NOT gate. Using the De-Morgan theorem, you can convert a NOR gate to an AND gate with inverted inputs where $(A + B)' = A' \cdot B'$.

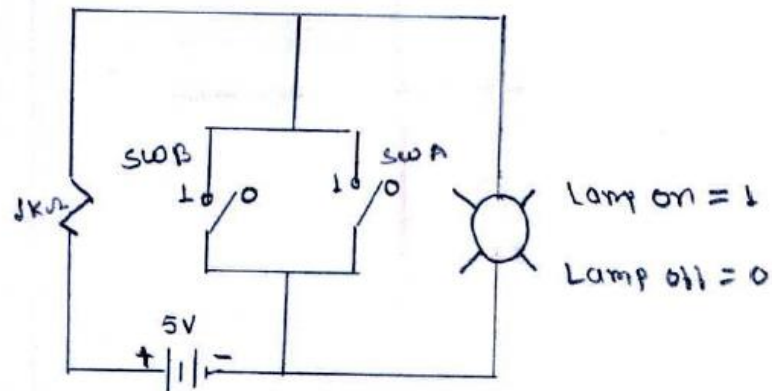

Figure:(13) Electrical circuit emulating a NOR gate

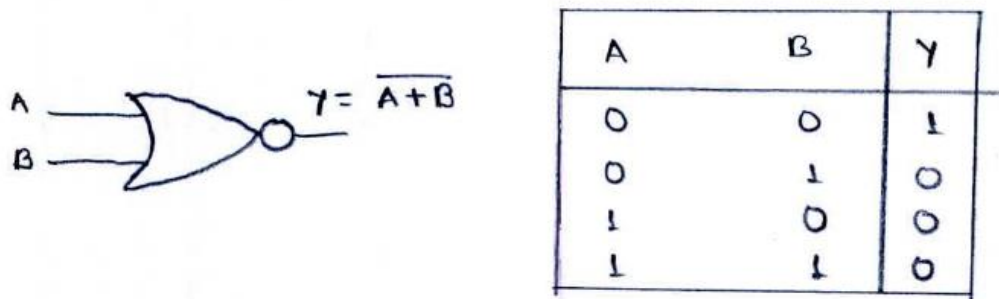

Figure:(14) Boolean expression, gate symbol & truth table for NOR gate

Procedure:

1. Connect mains cord to mains socket of **Scientech 2400I**.
2. Turn the Rocker switch (Power switch) in ON position.
3. Connect Serial Ethernet Cable between PLC and PC.
4. Open "**RSLogix Micro Starter**" software.
5. Create Ladder Logic Program
6. Simulate and Test Ladder Logic Program
7. Transfer Ladder Logic Program.
8. Verify the truth table of logic gates.

Ladder diagram

NOT GATE



AND GATE

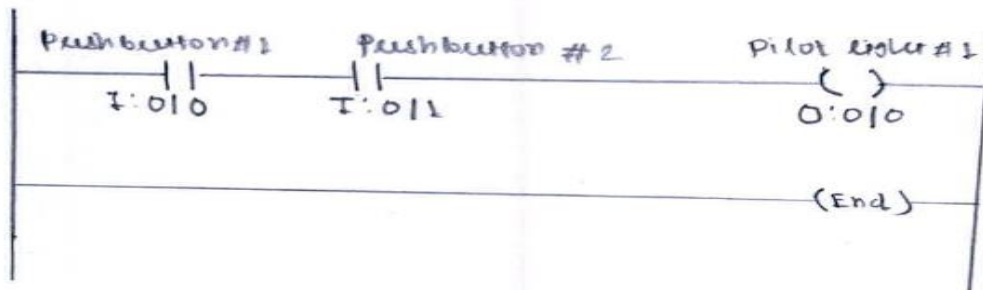

OR GATE

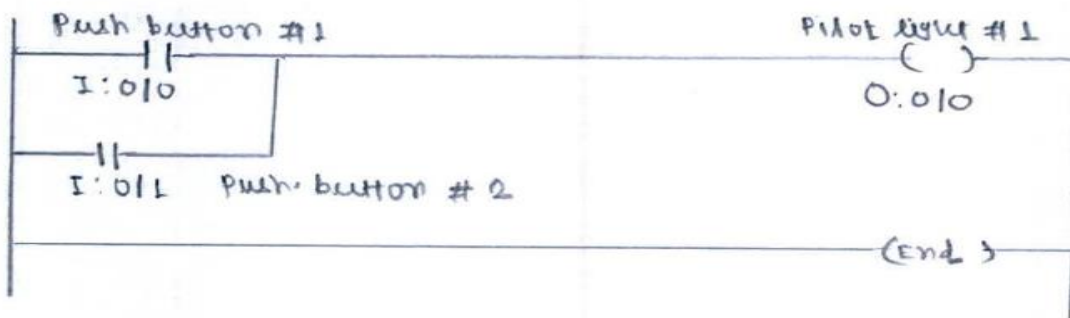

NAND GATE

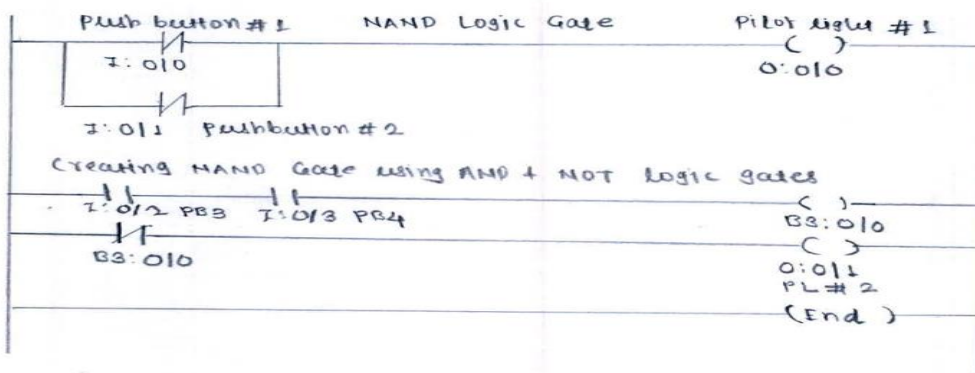

NOR GATE

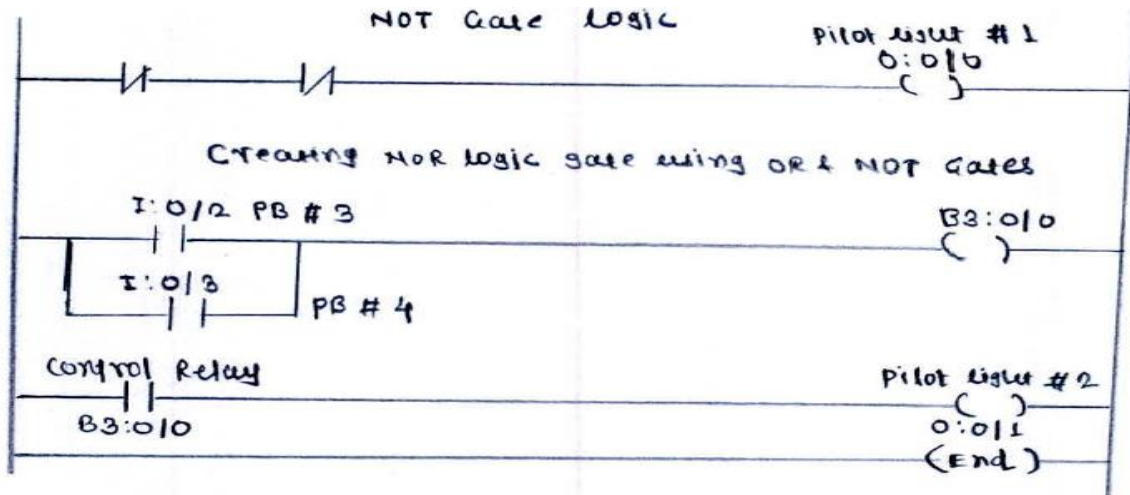

RESULT

EXPERIMENT NO: 10 IMPLIMENTATION OF FLIP FLOPS USING PLC

AIM:

To implement S-R Flip flop using PLC.

APPARATUS:

- Sciencetech 2400I Universal PLC Platform
- Ethernet Cable
- Mains cord

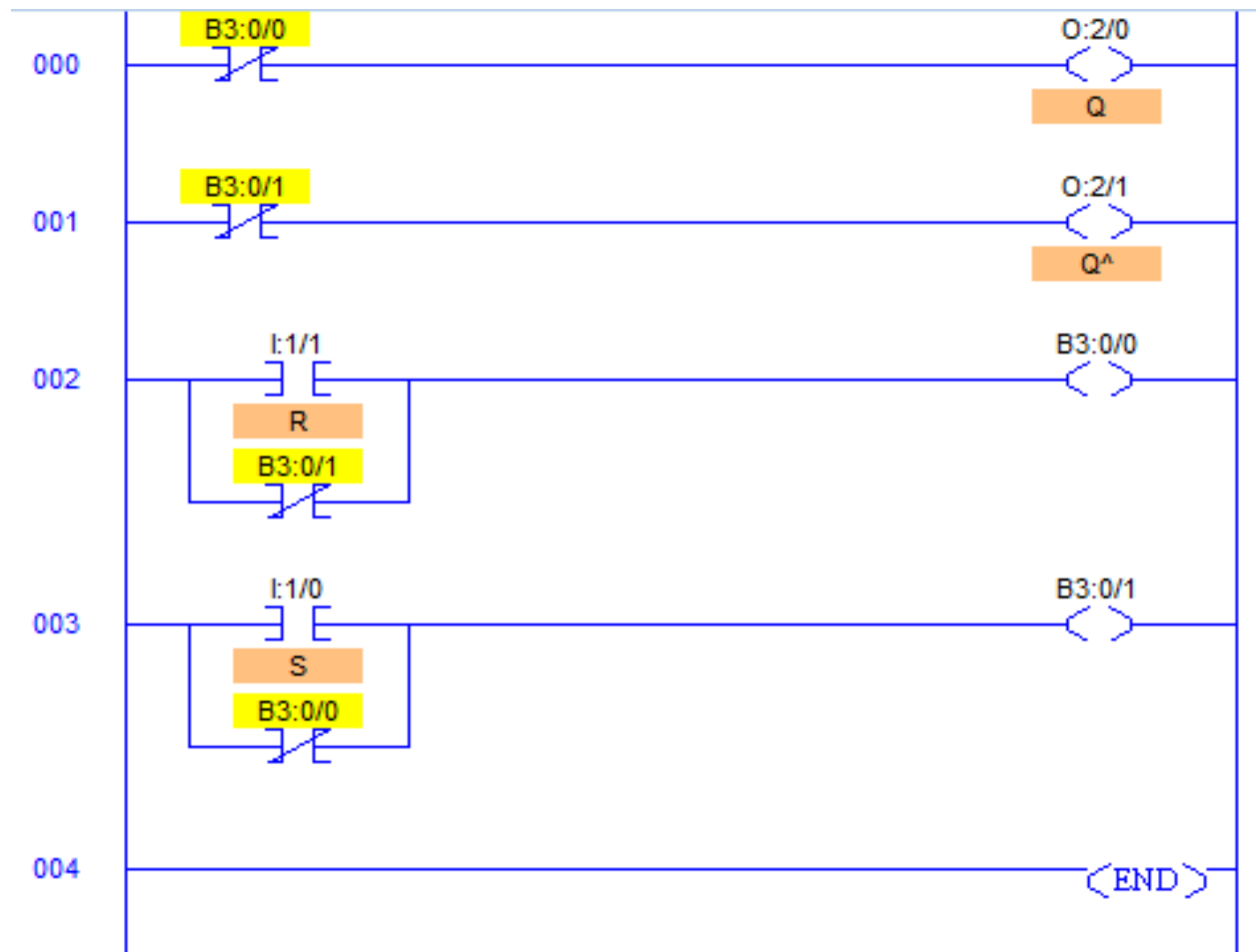

Program Description

- By definition, a condition of $Q (O:2/0) = 1$ and $Q^{\wedge} (O:2/1) = 0$ is Set and a condition of $Q (O:2/0) = 0$ and $Q^{\wedge} (O:2/1) = 1$ is Reset.
- If the signal state is high at input $I:1/0$ and low at $I:1/1$, bit $B3:0/1$ is set and output $O2:0/0$ is set to 1 which is a SET condition of this logic.
- Otherwise, if the signal state at input $I:1/0$ is low and at input $I:1/1$ is high, bit $B3:0/1$ is reset and output $O:2/0$ is reset which is a RESET condition of this logic.
- During power up, when both the inputs are low, $Q (O:2/0)$ will go high because of its order.
- And after either of the states is achieved, if both signal states go low, nothing is changed which is latched state.
- If both signal states are set to high, the Q^{\wedge} output $O:2/1$ instruction dominates because of the order in the ladder diagram, $B3:0/1$ is low and $B3:0/0$ is high causing Q output $O:2/0$ to reset.
- When $S I:1/0$ and $R I:1/1$ both are equal to 0, the outputs “latch” in their prior states.
- Slight delay may occur in inputs and resulting changes in outputs due to PLC’s program scan time.

Runtime Test Cases

Input		Output	
S	R	Q	Q^{\wedge}
0	0	Latch	Latch
0	1	0	1
1	0	1	0
1	1	0	0

RESULT

EXPERIMENT NO: 11 WATER LEVEL CONTROL USING PLC

AIM:

To control the water level in a tank using PLC..

APPARATUS:

- Sciencetech 2400I Universal PLC Platform
- The water level control trainer (**Sciencetech 2421**)
- 20 pin FRC cable to connect trainer with PLC
- Ethernet Cable
- Mains cord

THEORY

There is a need for engineers and technicians to be familiar with PLCs and to be able to program. The need to be connected to a physical system and be programmed correctly if they are to provide the quality of monitoring and control required. The experience and skill to be able to achieve this can best be obtained through practical hands-on use of a PLC connected to a real system. Water level control (**Sciencetech 2421**) enables students and practicing engineers to gain invaluable practical experience of the principles and application of programmable logic controllers.

The object is to connect and program an external programmable logic controller to monitor and control the level of water in a tank system. Water level controlling is shown with the help of LEDs. The apparatus is connected with output of PLC. Two valves for filling and draining water are shown, for indicating ON\OFF condition of valve LED is used. Filling of tank indicated by two sensors, positioned to sense maximum and minimum water levels of tank.

Truth Table

Sensor-1	Sensor-2	Valve-1	Valve-2
OFF	OFF	ON	OFF
ON	OFF	ON	OFF
ON	ON	OFF	ON

Procedure:

1. Connect mains cord to mains socket of **Sciencetech 2400I**.
3. Connect the water control trainer to the PLC board.
3. Turn the Rocker switch (Power switch) in ON position.
4. Connect Serial Ethernet Cable between PLC and PC.
5. Open “**RSLogix Micro Starter**” software.
6. Create Ladder Logic Program
7. Simulate and Test Ladder Logic Program
8. Transfer Ladder Logic Program.
9. Verify the truth table of logic gates.

RESULT

EXPERIMENT NO: 12

STEPPER MOTOR CONTROL USING PLC

AIM:

To control a stepper motor using PLC.

APPARATUS:

- Scientech 2400I Universal PLC Platform
- Scientech 2427 Module
- 20 pin FRC cable to connect trainer with PLC
- Ethernet Cable
- Mains cord

THEORY

A **stepper motor** is a brushless, synchronous electric motor that can divide a full rotation into a large number of steps, for example, 200 steps. When commutated electronically, the motor's position can be controlled precisely, without any feedback mechanism (see open loop control). A stepper motor's design is virtually identical to that of a low-speed synchronous AC motor. In that application, the motor is driven with two phase AC, one phase usually derived through a phase shifting capacitor. Another similar motor is the switched reluctance motor, which is a very large stepping motor with a reduced pole count, and generally closed-loop commutated. Stepper motors work on the principle of electromagnetism. There is a soft iron or magnetic rotor shaft surrounded by the electromagnetic stators. The rotor and stator have poles which may be teathed or not depending upon the type of stepper. When the stators are energized the rotor moves to align itself along with the stator (in case of a permanent magnet type stepper) or moves to have a minimum gap with the stator (in case of a variable reluctance stepper). This way the stators are energized in a sequence to rotate the stepper motor. The control sequence for rotating the motor is shown in the table given below. The respective windings should be made high according to the sequence given in the table and the controller very well executes this function.

Clockwise control

Y0, Y1, Y2, Y3 are Controlled in following order

Y0	Y1	Y2	Y3	Step angle
0	1	0	1	0°
1	0	0	1	90°
1	0	1	0	180°
0	1	1	0	270°

Counter clockwise control

Y0, Y1, Y2, Y3 are Controlled in following order

Y0	Y1	Y2	Y3	Step angle
0	1	0	1	- 0°
0	1	1	0	-90°
1	0	1	0	-180°
1	0	0	1	-270°

PROCEDURE

1. Connect mains cord to mains socket of **Scientech 2400I**.
3. Connect the water control trainer to the PLC board.
3. Turn the Rocker switch (Power switch) in ON position.
4. Connect Serial Ethernet Cable between PLC and PC.
5. Open “**RSLogix Micro Starter**” software.
6. Create Ladder Logic Program
7. Simulate and Test Ladder Logic Program
8. Transfer Ladder Logic Program.
9. Then put the PLC in RUN mode.

LADDER DIAGRAM



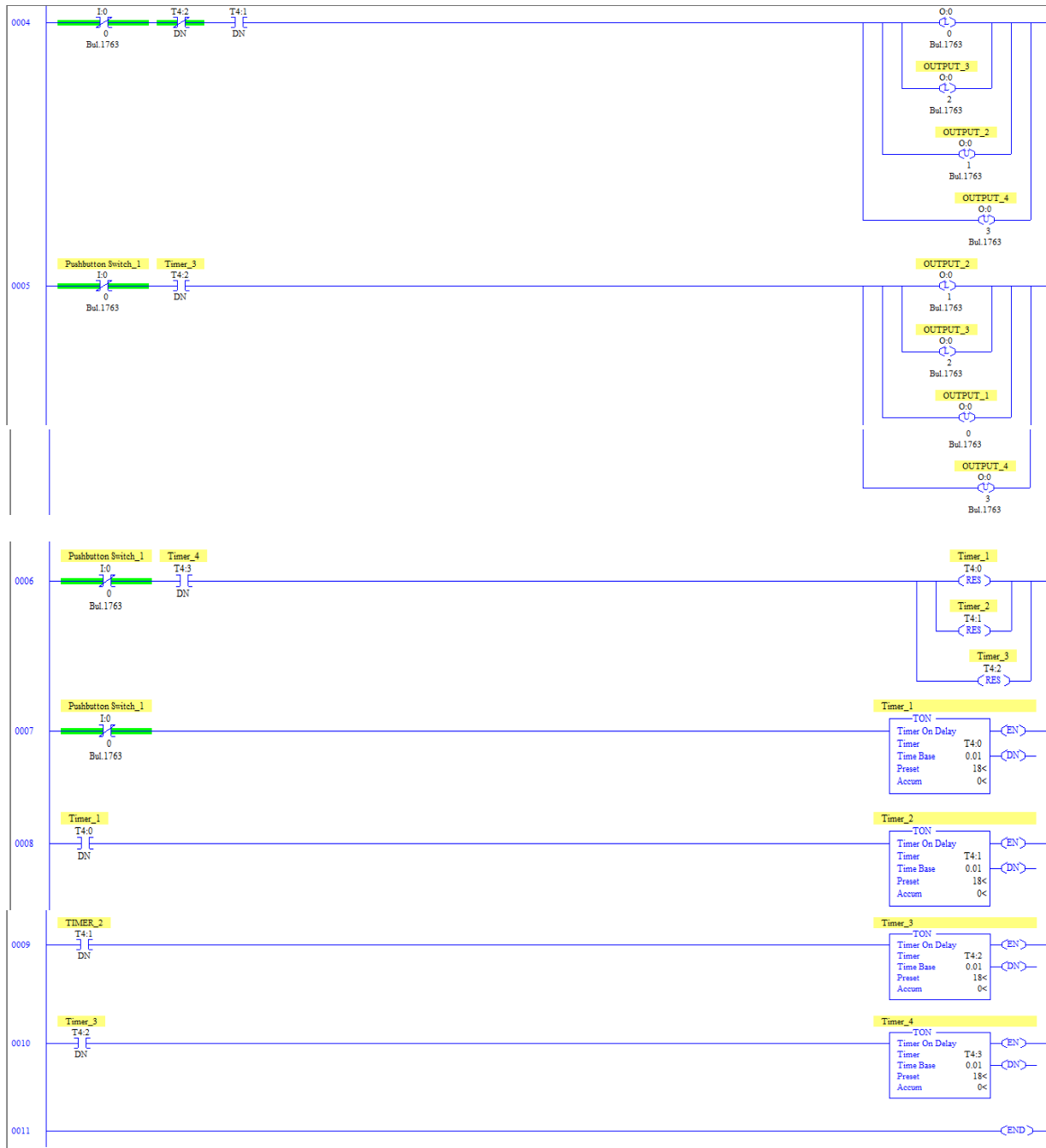

RESULT

ADDITIONAL/ADVANCED EXPERIMENTS

EXPERIMENT-13

CONVEYOR SYSTEM USING PLC

Aim: - Conveyor system using PLC

Apparatus:

- Sciencetech 2400I Universal PLC Platform
- The water level control trainer (**Sciencetech 2421**)
- 20 pin FRC cable to connect trainer with PLC
- Ethernet Cable
- Mains cord

Theory: -

The Figure 3.1 illustrates a bottle-filling motion control process. This application requires two axes of motion: the motor operating the bottle filler mechanism and the motor controlling the conveyor speed. The role of each control component can be summarized as follows:

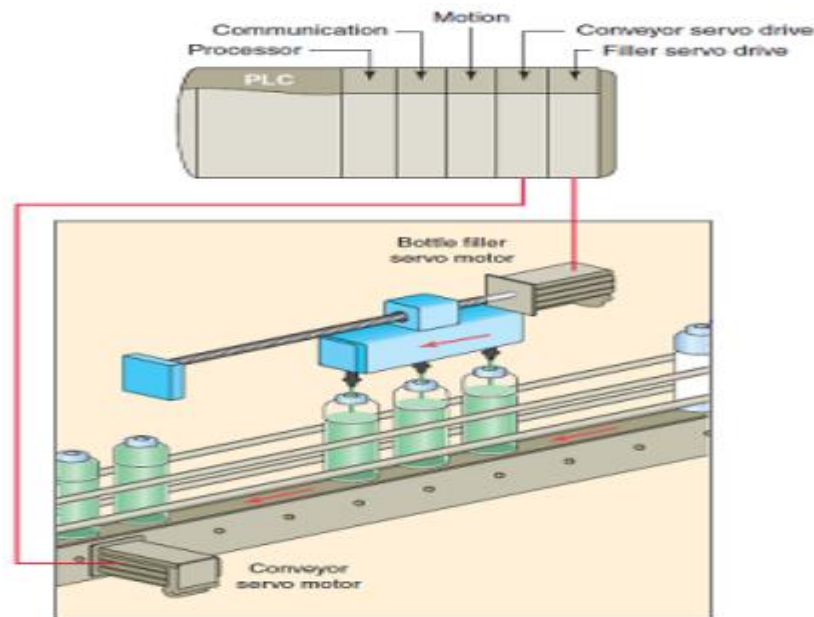

Fig 3.1: Bottle filling control process

Procedure:

1. Connect mains cord to mains socket of **Sciencetech 2400I**.
3. Connect the water control trainer to the PLC board.
3. Turn the Rocker switch (Power switch) in ON position.
4. Connect Serial Ethernet Cable between PLC and PC.

5. Open “RSLogix Micro Starter” software.
6. Create Ladder Logic Program
7. Simulate and Test Ladder Logic Program
8. Transfer Ladder Logic Program.
9. Verify the truth table of logic gates.

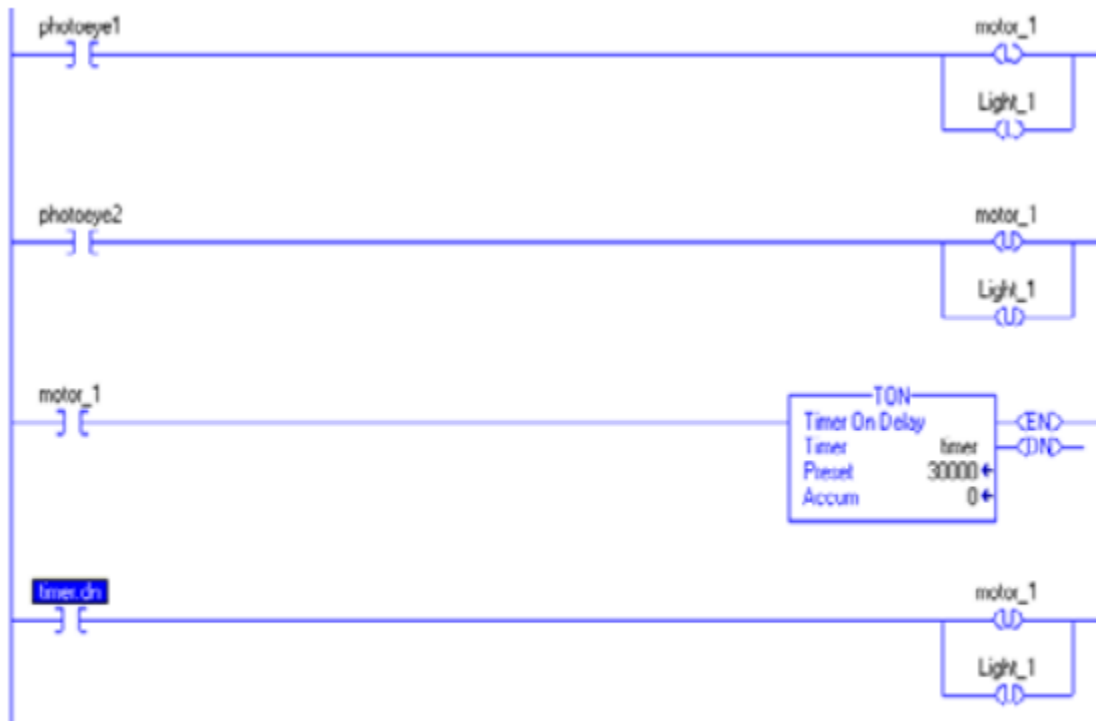

Fig 4.3: Relay ladder logic

RESULT

EXPERIMENT: - 14

COMBINATION OF LOGIC GATES USING PLC

AIM:

Combination of logic gates using PLC

APPARATUS:

- Sciencetech 2400I Universal PLC Platform
- Ethernet Cable
- Mains cord

THEORY:

The majority of PLC manufacturers use the ladder logic diagram programming language to program their programmable logic controllers (PLCs). Some manufacturers prefer using logic gate circuits or Boolean expressions to program their PLCs. Therefore, it is beneficial to know how to convert one type of PLC programming language to the other.

4. NAND GATE

NAND gate is operated as an AND gate and followed by the inverter.

Working: In NAND Gate, the output will be low when both inputs are high. For all other cases, the output will be high.

Logic Gate Truth Table for NAND Gate:

Input (I1)	Input (I2)	Output (Q1)
0	0	1
0	1	1
1	0	1
1	1	0

NAND Gate in PLC programming:

If both switches (I1 and I2) or anyone switch (I1 or I2) are closed, the lamp will be glow. In the case, both switches are open then the lamp will not be glow.

Symbolic Representation as,

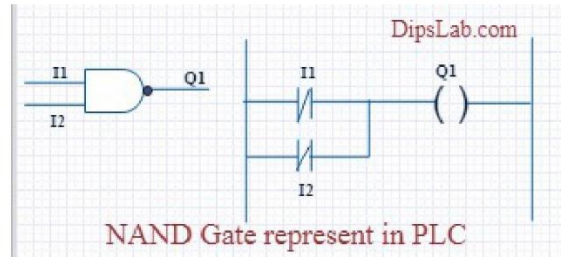

5. NOR GATE

NOR Gate is operated OR Gate followed by the NOT Gate.

When both inputs are low then the output will be high. Otherwise, the low output will occur if both inputs are high.

Logic Gate Truth Table for NOR Gate:

Input (I1)	Input (I2)	Output (Q1)
0	0	1
0	1	0
1	0	0
1	1	0

NOR Gate in PLC programming:

The Coil (Q1) will be activated if both inputs are closed. Coil (Q1) will be deactivated if anyone or Bothe the inputs are open.

Symbolic Representation as,

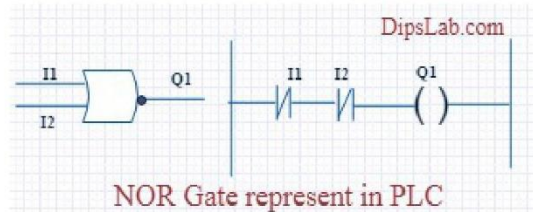

6. EX-OR GATE

Working: If both inputs are high or low, the output will become low. For any other input condition, the output will be high.

Logic Gate Truth Table for EX-OR Gate:

Input (I1)	Input (I2)	Output (Q1)
0	0	0
0	1	1
1	0	1
1	1	0

EX-OR Gate in PLC programming:

In the function of EX-OR Gate, the lamp will be on if one switch is closed and another switch is opened.

Symbolic Representation as,

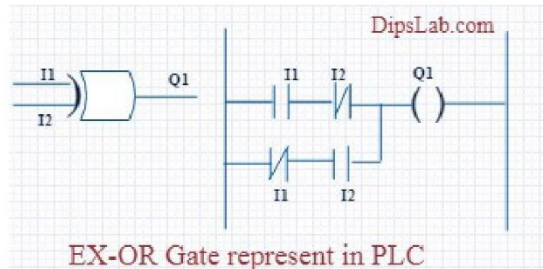

7. EX-NOR GATE

Working: When both inputs (I1 and I2) are high or low then the output will high. If anyone input is high or low then the output will become low.

Logic Gate Truth Table for EX-NOR Gate:

Input (I1)	Input (I2)	Output (Q1)
0	0	1
0	1	0
1	0	0
1	1	1

EX_NOR gate in PLC programming:

The function of EX-NOR Gate, the lamp (Q1) will be on if both switches (I1 and I2) are open or closed. The lamp (Q1) will not be on if anyone switches (I1) is activated and another switch (I2) is deactivated.

Symbolic Representation as,

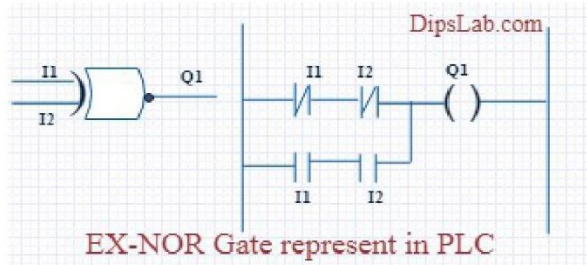

Procedure:

- Connect two switches to the digital input module.
- Connect one LED to the digital output module.
- Write down the ladder diagram to implement AND-logic function using SIMATIC Manager software.
- Download the program to the PLC.
- Repeat steps 1 through 4 to implement OR-logic function.
- Repeat steps 1 through 4 to implement Parallel NOT-logic function.

RESULT